

DIMENSIONS 104-107

Section Effective Replaces Pg 1/2
 104 APRIL 2003 NOVEMBER 1999

TYPE

SIZE

UNIT STYLE

SNP
 SNPJ

2.5
 2.5

PO



RIGHT HAND ROTATION. FOR LEFT HAND ROTATION, PUMP SHAFT PROJECTION IS OPPOSITE THAT SHOWN.

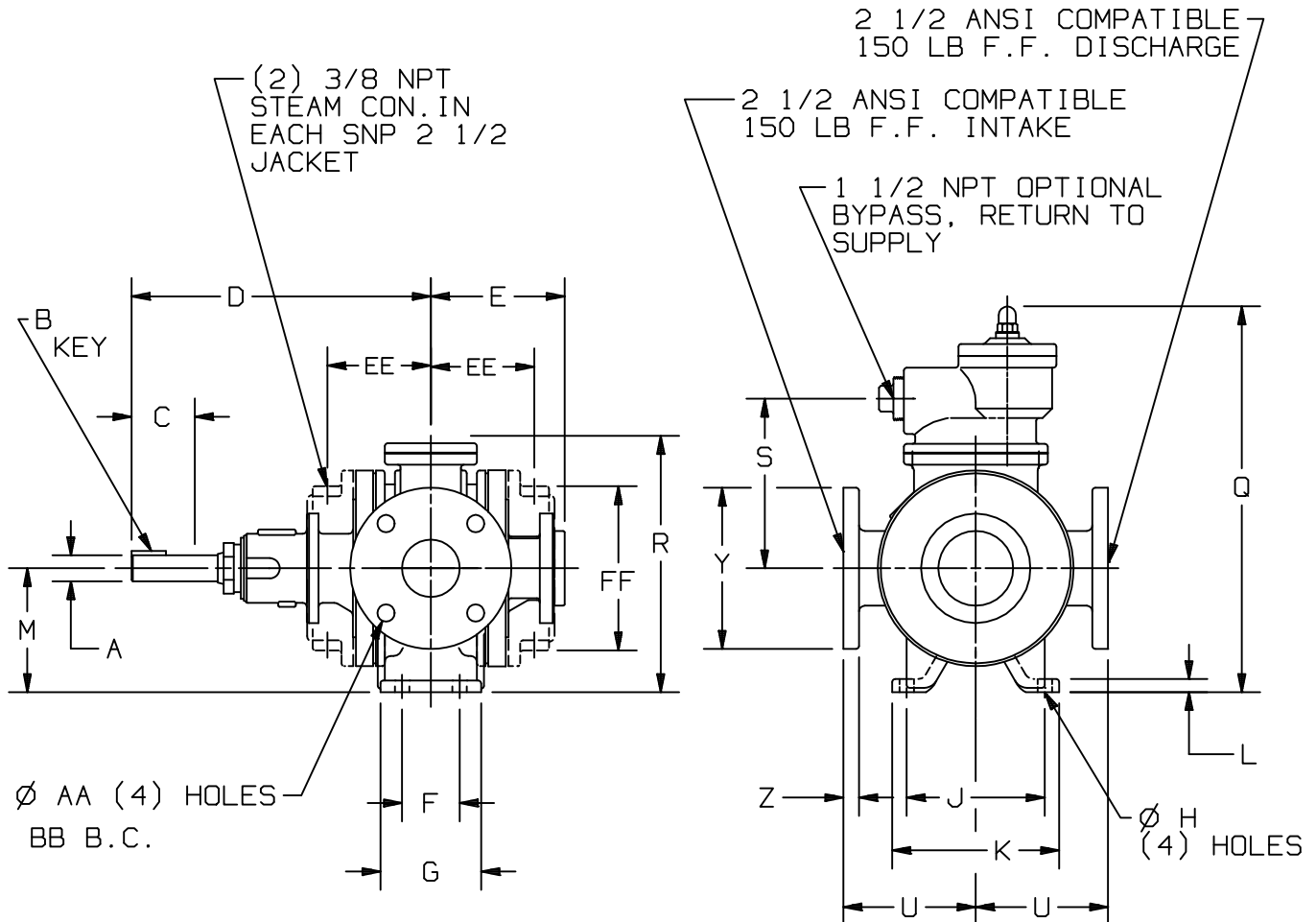

SNPJ - 140 LBS, 63,5 KG
 SNP - 120 LBS, 54,4 KG

			UNITS	DIMENSIONS											
FRAME SIZE	PUMP SIZE			A	B	C	D	E	F	G	H	J	K	L	M
	SNP2.5	IN	1 1/8	1/4	2 3/4	13	5 13/16	2 1/2	4 3/8	5/8	6	7 1/4	9/16	5 3/8	
		MM	28,6	6,4	69,9	330,2	147,6	63,5	111,1	15,9	152,4	184,1	14,3	136,5	
			N	P	Q	R	S	T	U	V	W	X	Y	Z	
	SNP2.5	IN	—	—	16 1/2	11 1/8	7 3/16	—	5 3/4	—	—	—	7	11/16	
		MM	—	—	419,1	282,6	182,6	—	146	—	—	—	177,8	17,5	
			AA	BB	CC	DD	EE	FF							
	SNP2.5	IN	3/4	5 1/2	—	—	4 3/8	7 1/8							
		MM	19,1	139,7	—	—	111,1	181							

DIMENSIONS 104-107

Section 104
 Effective APRIL 2003
 Replaces OCTOBER 2001
 Page 2/2

TYPE
 SNP-SNPJ

SIZE
 2.5

UNIT
 STYLE
 HRA



RIGHT HAND ROTATION. FOR LEFT HAND ROTATION, INTAKE, DISCHARGE, AND RELIEF VALVE ARE OPPOSITE THAT SHOWN.

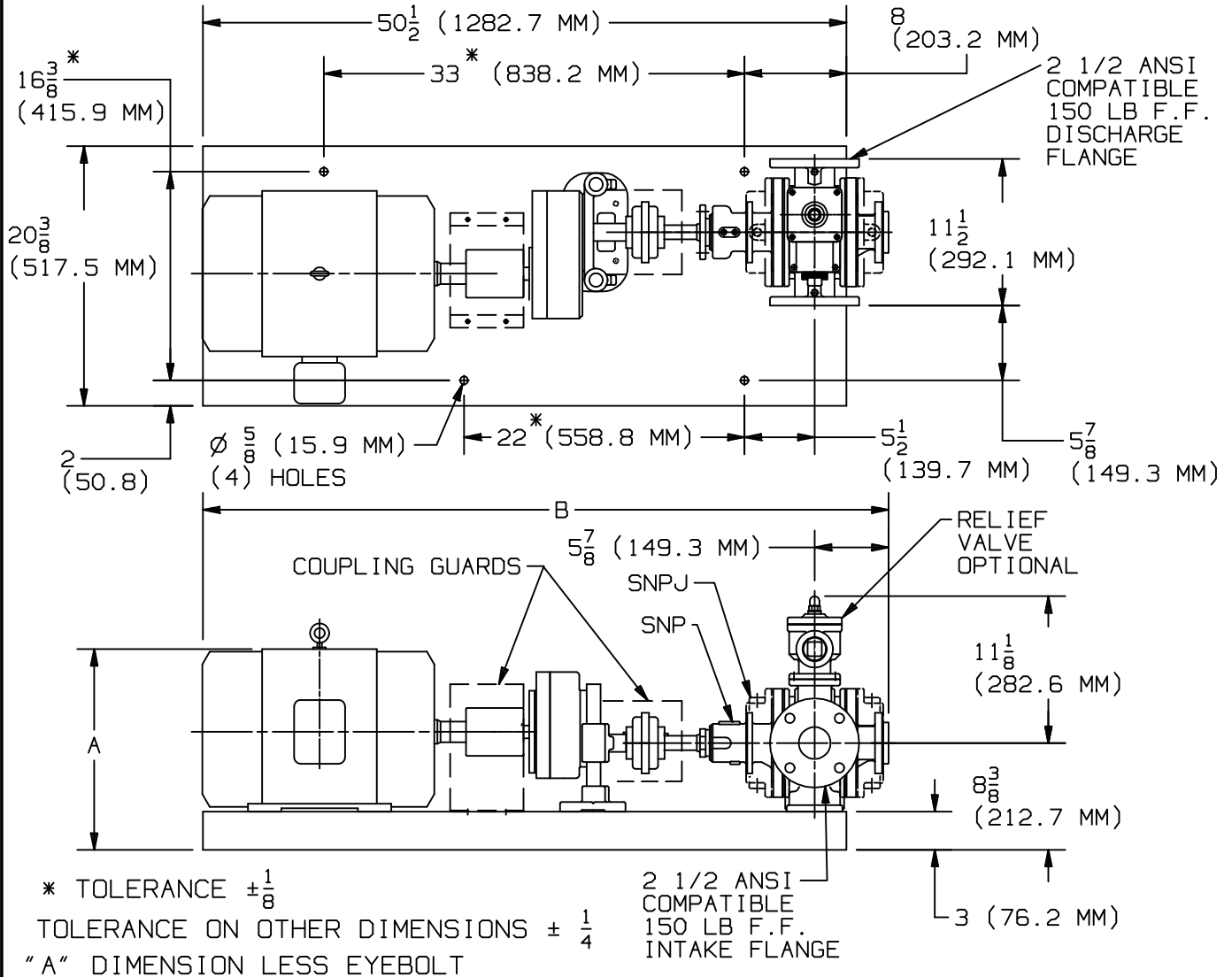

MOTOR			BASE NO.	DIMENSIONS						APPROX. UNIT WT. - POUNDS / KG			
FRAME SIZE				UNITS	A	B			UNITS	LESS MOTOR	INCL. MOTOR	LESS MOTOR	INCL. MOTOR
182T		901684	IN	12 5/8	54 5/8			LBS	369	439	389	459	
			MM	320.7	1387.5			KG	167.3	199.1	176.4	208.2	
184T		901684	IN	12 5/8	54 5/8			LBS	369	457	389	477	
			MM	320.7	1387.5			KG	167.3	207.3	176.4	216.3	
213T		901684	IN	14 1/8	54 5/8			LBS	369	479	389	499	
			MM	358.8	1387.5			KG	167.3	217.2	176.4	226.3	
215T		901684	IN	14 1/8	54 5/8			LBS	369	499	389	519	
			MM	358.8	1387.5			KG	167.3	226.3	176.4	235.4	
254T		901684	IN	16 3/8	55 7/8			LBS	369	599	389	619	
			MM	415.9	1419.2			KG	167.3	271.7	176.4	280.7	
256T		901684	IN	16 3/8	57 7/8			LBS	369	634	389	654	
			MM	415.9	1470.0			KG	167.3	287.5	176.4	296.6	