

# BLACKMER PARTS LIST

## MODELS: STX1220A , STX1220A-DEF <sup>1</sup>

Keep with Instructions 203-A00 for Installation, Operation and Maintenance

961830 **PARTS LIST**  
Page 1 of 2 **203-A03**

Section 203  
Effective Mar 2014  
Replaces Mar 2012

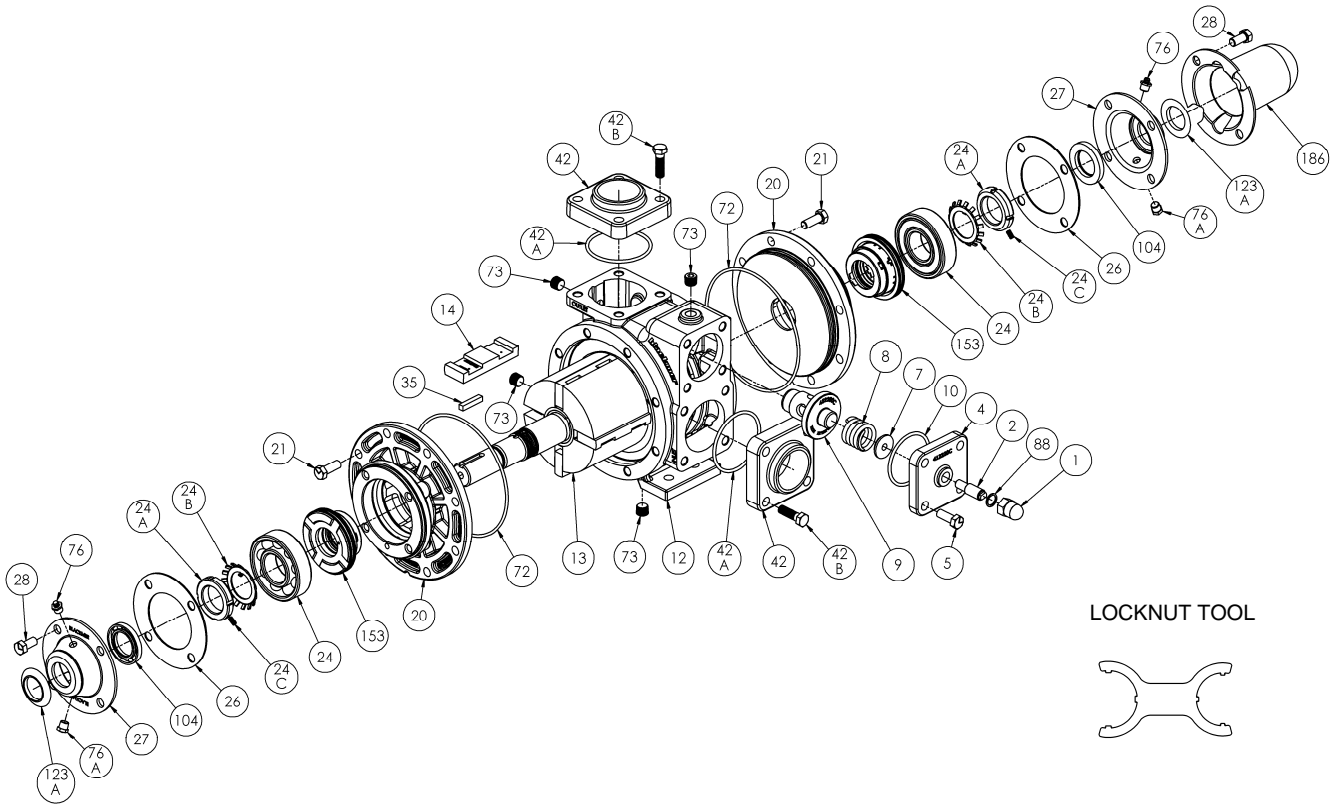

REF. NO.	DESCRIPTION	PARTS PER PUMP	PART NO.	REF. NO.	DESCRIPTION	PARTS PER PUMP	PART NO.
1	Cap – Relief Valve (R/V)	1	413151	24C	Setscrew – Locknut	2	924060
2	Adjusting Screw – R/V	1	432220	26	Gasket – Bearing Cover	2	381406
4	Cover – R/V	1	412220	27	Bearing Cover	0 – 1	042220
5	Capscrew – R/V Cover	4	920335	28	Capscrew – Bearing Cover	12	920293
7	Spring Guide – R/V	1	423101	35	Key – Shaft	1	909209
8	Spring – R/V (51- 75 psi)	1	471418	42	Flange – 2” Weld	2	651433
	Spring – R/V (76 –110 psi)		471427	42A	O-Ring – Flange, PTFE	2	702056
	Spring – R/V (111-125 psi)		471429	42B	Capscrew – Flange	8	920365
9	Valve – R/V	1	452200	72	O-Ring – Head; PTFE	2	712007
10	O-Ring – R/V Cover, PTFE	1	711999	73	Plug – ¼” NPT	4	908192
12	Cylinder	1	022220	76	Grease Fitting	2	317815
13	Rotor & Shaft	1	262220	76A	Grease Relief Fitting	2	701992
14	Vane – Duravane	4	091419	88	Seal Ring – R/V Cap, PTFE	1	533101
20	Head	2	032220	104	Oil Seal	2	331918
21	Capscrew – Head	20	920335	123A	Dirt Shield	2	701480
24	Bearing	2	903156	153	Mechanical Seal	2	See back
24A	Locknut w/setscrew	2	903583	186	Shaft Protector	1	341601
24B	Lockwasher	2	903522		Tool – Locknut		903091

<sup>1</sup> STX1220A-DEF model requires special cleaning/testing. Consult factory if not familiar with these procedures.

**MECHANICAL SEAL**

REF. NO.	DESCRIPTION	PARTS PER PUMP	PART NO.
153	Mechanical Seal Complete – Silicon Carbide Stationary Seat, PTFE O-Ring, Custom Carbon Rotating Seal Face with PTFE Seal Ring (LACT)	2	332221
153D	O-Ring – Stationary (PTFE)	2	702056
153L	O-Ring – Rotating (PTFE)	2	702109

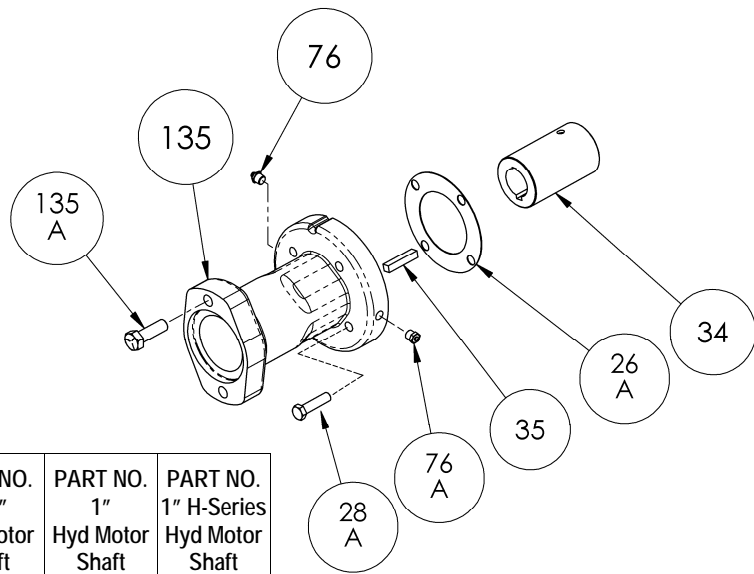
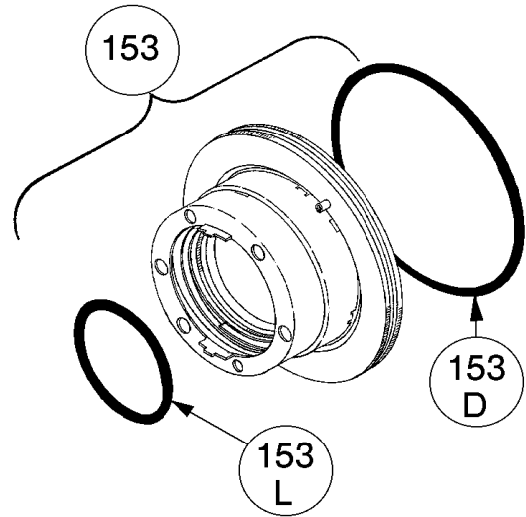

**OPTIONAL HYDRAULIC MOTOR ADAPTER**

REF. NO.	PART NAME	PARTS PER PUMP	PART NO. 1-1/4" Hyd Motor Shaft	PART NO. 1" Hyd Motor Shaft	PART NO. 1" H-Series Hyd Motor Shaft
See Below	<b>Hydraulic Motor Adapter Kit *</b>	See Below	891458	891205	891464
26A	Gasket – Hydraulic Motor Adapter	1	383940	383940	383940
28A	Capscrew – Hydraulic Motor Adapter / Head	4	920369	920369	920369
34	Coupling w/ Setscrew – for straight key hyd. motor shaft	1	906967	906966	906966
35	Key – Coupling	1	909184	N/A	N/A
76	Grease Fitting	1	317815	317815	317815
76A	Grease Relief Fitting	1	701992	701992	701992
135	Hydraulic Motor Adapter – SAE A Flange	1	041828	041827	041807
135A	Capscrew – Adapter / Motor	2	920510	920510	920510



1809 Century Avenue, Grand Rapids, Michigan 49503-1530, U.S.A.  
 Telephone: (616) 241-1611 / Fax: (616) 241-3752  
 E-mail: [blackmer@blackmer.com](mailto:blackmer@blackmer.com) / Internet: [www.blackmer.com](http://www.blackmer.com)