

WILDEN®

EOM
Engineering
Operation &
Maintenance

H800
Metal Pump

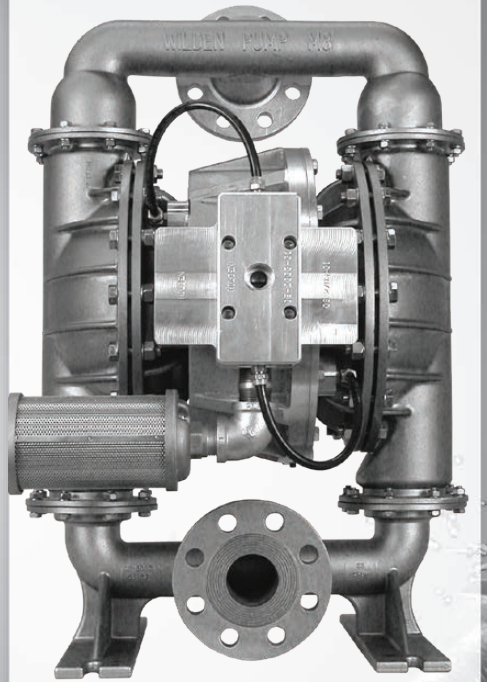

Where Innovation Flows

wildenpump.com

a **DOVER** company

TABLE OF CONTENTS

SECTION 1 CAUTIONS—READ FIRST!1

SECTION 2 WILDEN PUMP DESIGNATION SYSTEM2

SECTION 3 HOW IT WORKS—PUMP3

SECTION 4 DIMENSIONAL DRAWINGS4

SECTION 5 PERFORMANCE5

SECTION 6 SUGGESTED INSTALLATION, OPERATION & TROUBLESHOOTING6

SECTION 7 DISASSEMBLY / REASSEMBLY

 Pump Disassembly9

 Air Valve / Center-Section Disassembly13

 Power Cylinder Disassembly15

SECTION 8 EXPLODED VIEW & PARTS LISTING

 H800 Metal - Ductile Iron18

 H800 Metal - Stainless Steel19

 H800 Metal - Center Section20

SECTION 9 ELASTOMER OPTIONS22

CAUTIONS—READ FIRST!



TEMPERATURE LIMITS:

Acetal	-29°C to 82°C	-20°F to 180°F
Buna-N	-12°C to 82°C	10°F to 180°F
Geolast®	-40°C to 82°C	-40°F to 180°F
Neoprene	-18°C to 93°C	0°F to 200°F
Nordel® EPDM	-51°C to 138°C	-60°F to 280°F
Nylon	-18°C to 93°C	0°F to 200°F
PFA	-7°C to 107°C	45°F to 225°F
Polypropylene	0°C to 79°C	32°F to 175°F
Polyurethane	-12°C to 66°C	10°F to 150°F
PVDF	-12°C to 107°C	10°F to 225°F
Saniflex™	-29°C to 104°C	-20°F to 220°F
SIPD PTFE with EPDM-backed	4°C to 137°C	40°F to 280°F
SIPD PTFE with Neoprene-backed	4°C to 93°C	40°F to 200°F
PTFE ¹	4°C to 104°C	40°F to 220°F
FKM	-40°C to 177°C	-40°F to 350°F
Wil-Flex™	-40°C to 107°C	-40°F to 225°F

¹4°C to 149°C (40°F to 300°F) - 13 mm (1/2") and 25 mm (1") models only.

NOTE: Not all materials are available for all models. Refer to Section 2 for material options for your pump.



CAUTION: When choosing pump materials, be sure to check the temperature limits for all wetted components. Example: FKM has a maximum limit of 177°C (350°F), but polypropylene has a maximum limit of only 79°C (175°F).



CAUTION: Maximum temperature limits are based upon mechanical stress only. Certain chemicals will significantly reduce maximum safe operating temperatures. Consult Chemical Resistance Guide for chemical compatibility and temperature limits.



WARNING: Prevent static sparking — If static sparking occurs, fire or explosion could result. Pump, valve and containers must be grounded to a proper grounding point when handling flammable fluids and whenever discharge of static electricity is a hazard.



CAUTION: Do not exceed 5.9 bar (85 psig) air supply pressure.



CAUTION: All piping, valves, gauges and other components installed on the liquid discharge must have a minimum pressure rating of 20.7 bar (300 psig).



CAUTION: The discharge pressure generated by this pump is three times (3x) the inlet pressure supplied.



CAUTION: The process fluid and cleaning fluids must be chemically compatible with all wetted pump components. Consult Chemical Resistance Guide.



CAUTION: Pumps should be thoroughly flushed before installing into process lines. FDA- and USDA approved pumps should be cleaned and/or sanitized before being used.



CAUTION: Always wear safety glasses when operating pump. If diaphragm rupture occurs, material being pumped may be forced out air exhaust.



CAUTION: Before any maintenance or repair is attempted, the compressed air line to the pump should be disconnected and all air pressure allowed to bleed from pump. Disconnect all intake, discharge and air lines. Drain the pump by turning it upside down and allowing any fluid to flow into a suitable container.



CAUTION: Blow out air line for 10 to 20 seconds before attaching to pump to make sure all pipeline debris is clear. Use an in-line air filter. A 5µ (micron) air filter is recommended.



NOTE: Before starting disassembly, mark a line from each liquid chamber to its corresponding air chamber. This line will assist in proper alignment during reassembly.



CAUTION: Wilden H800 High-Pressure pumps cannot be used in submersible applications.



CAUTION: Tighten all hardware prior to installation.



WILDEN PUMP DESIGNATION SYSTEM

H800 METAL

**51 mm (2") Pump
Maximum Flow Rate:
360 lpm (95 gpm)**

LEGEND

XH800 / XXXXX / XXX / XX / XXX / XXXX

MODEL

WETTED PARTS & OUTER PISTON

AIR CHAMBERS

CENTER BLOCK

AIR VALVE

DIAPHRAGMS

VALVE BALLS

O-RINGS

VALVE SEATS

SPECIALTY CODE

(if applicable)

MATERIAL CODES

MODEL

H800 = 51 mm (2") HIGH-PRESSURE
XH800 = 51 mm (2") HIGH-PRESSURE ATEX

WETTED PARTS & OUTER PISTON

HH = ALLOY C/ALLOY C
HZ = ALLOY C/NO OUTER PISTON
SS = STAINLESS STEEL/
STAINLESS STEEL
SZ = STAINLESS STEEL/
NO OUTER PISTON
WW = DUCTILE IRON/
DUCTILE IRON
WZ = DUCTILE IRON/
NO OUTER PISTON

AIR CHAMBERS

S = STAINLESS STEEL
W = DUCTILE IRON

CENTER BLOCK

A = ALUMINUM

AIR VALVE

A = ALUMINUM

DIAPHRAGMS

FWL = FULL-STROKE
SANITARY
WIL-FLEX™ IPD¹
FWS = SANITARY
WIL-FLEX™¹
TWS = FULL-STROKE PTFE
W/WIL-FLEX™
BACKUP
WWL = FULL-STROKE
WIL-FLEX™ IPD

VALVE BALLS

FW = SANITARY WIL-FLEX™
[SANTOPRENE® (TWO
ORANGE DOTS)]
TF = PTFE (WHITE)
WF = WIL-FLEX™
[SANTOPRENE®
(ORANGE DOT)]

VALVE SEATS

H = ALLOY C
S = STAINLESS STEEL
M = MILD STEEL

VALVE SEAT O-RINGS

TF = PTFE (WHITE)
WF = WIL-FLEX™
[SANTOPRENE®
(ORANGE DOT)]

¹Meets Requirements of FDA CFR21.177

SPECIALTY CODES

0504 DIN flange

NOTE: MOST ELASTOMERIC MATERIALS USE COLORED DOTS FOR IDENTIFICATION.

NOTE: NOT ALL MODELS ARE AVAILABLE WITH ALL MATERIAL OPTIONS.

HOW IT WORKS—PUMP

The Wilden diaphragm pump is an air-operated, positive displacement, self-priming pump. These drawings show flow pattern through the pump upon its initial stroke. It is assumed the pump has no fluid in it prior to its initial stroke.

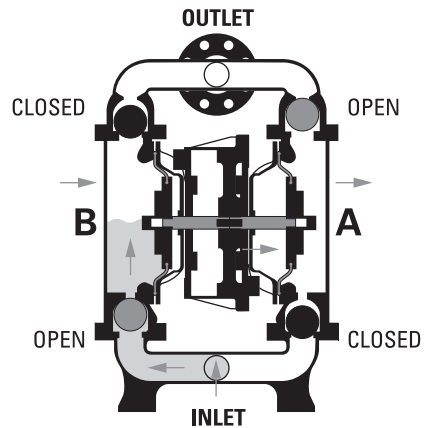

FIGURE 1 When air pressure is supplied to the pump, the air valve directs pressure to the back side of diaphragm A. The compressed air moves the diaphragm away from the center section of the pump. The opposite diaphragm is pulled in by the shaft connected to the pressurized diaphragm. Diaphragm B is on its suction stroke; air behind the diaphragm has been forced out to the atmosphere through the exhaust port. The movement of diaphragm B towards the center section of the pump creates a vacuum within chamber B. Atmospheric pressure forces fluid into the inlet manifold forcing the inlet valve ball off of its seat. Liquid is free to move past the inlet valve ball and fill the liquid chamber (see shaded area).

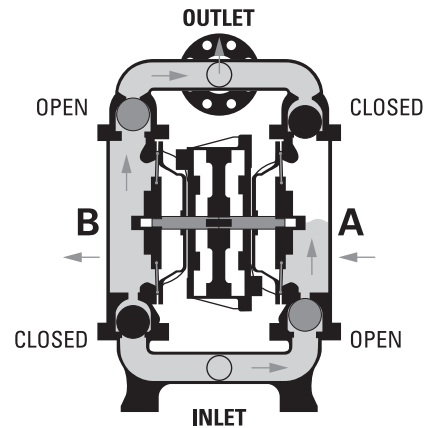

FIGURE 2 Once the shaft has reached the end of its stroke, the air valve redirects pressurized air to the back side of diaphragm B.

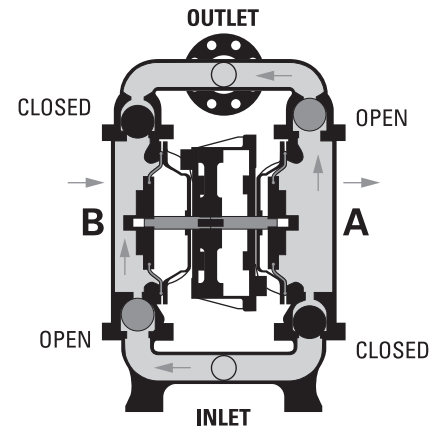

FIGURE 3 At completion of the stroke, the air valve again redirects air to the back side of diaphragm A, which starts diaphragm B on its exhaust stroke. As the pump reaches its original starting point, each diaphragm has gone through one exhaust and one discharge stroke. This constitutes one complete pumping cycle. The pump may take several cycles to completely prime depending on the condition of the application.

HOW IT WORKS—THE POWER PRINCIPLE

The H800 uses an integral power-amplifier piston together with two diaphragms to yield a pressure ratio of 3:1 (e.g., 85 psig air inlet will develop pump discharge pressures up to 250 psig). Air is simultaneously directed behind the amplifier piston as well as one of the diaphragms via specialized air manifold porting. The sum of the two surface areas is three times that of the diaphragm. Therefore, the discharge is amplified by a 3:1 pressure output ratio.

DIMENSIONAL DRAWINGS

H800 Metal

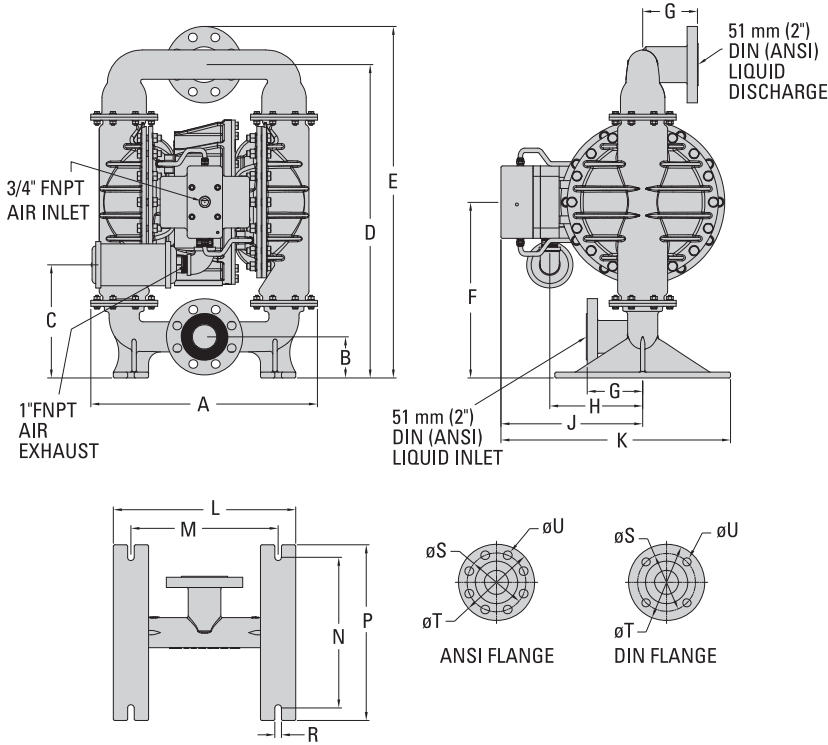

DIMENSIONS

ITEM	Metric (mm)	Standard (inch)
A	490	19.3
B	89	3.5
C	245	9.6
D	677	26.7
E	760	29.9
F	378	14.9
G	120	4.7
H	201	7.9
J	307	12.1
K	498	19.6
L	394	15.5
M	318	12.5
N	325	12.8
P	379	14.9
R	14	0.6
ANSI FLANGE 300 lb		
S	127 DIA.	5.0 DIA.
T	165 DIA.	6.5 DIA.
U	19 DIA.	0.8 DIA.
DIN FLANGE PN40		
S	125 DIA.	4.9 DIA.
T	165 DIA.	6.5 DIA.
U	18 DIA.	0.7 DIA.

LW0192 REV. B



PERFORMANCE (TPE/FULL-STROKE PTFE)

H800 METAL

Ship Weight.....Stainless Steel 128 kg (283 lb)
 Ductile Iron 128 kg (283 lb)
 Alloy C 134 kg (295 lb)
 Air Inlet19 mm (3/4")
 Inlet 51 mm (2")
 Outlet 51 mm (2")
 Suction Lift 3.7 m Dry (12.0')
 9.0 m Wet (29.5')
 Disp. Per Stroke¹ 1.67 L (0.44 gal)
 Max. Flow Rate 360 lpm (95 gpm)
 Max. Size Solids..... 12.7 mm (1/2")

¹Displacement per stroke was calculated at 4.8 bar (70 psig) air inlet pressure against a 5.1 bar (75 psig) head pressure.

Example: To pump 76 lpm (20 gpm) against a discharge pressure head of 8.6 bar (125 psig) requires 2.9 bar (42 psig) and 65 Nm³/h (38 scfm) air consumption.

Caution: Do not exceed 5.9 bar (85 psig) air supply pressure.

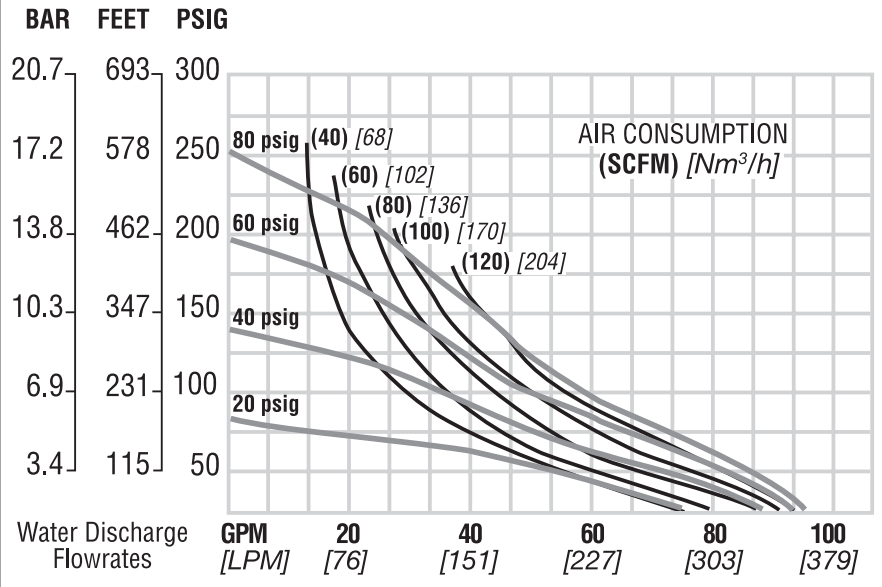

Flow rates indicated on chart were determined by pumping water. For optimum life and performance, pumps should be specified so that daily operation parameters will fall in the center of the pump's performance curve.

SUCTION-LIFT CURVE

H800 METAL
 SUCTION-LIFT CAPABILITIES

Suction-lift curves are calibrated for pumps operating at 305 m (1,000') above sea level. This chart is meant to be a guide only. There are many variables that can affect your pump's operating characteristics. The number of intake and discharge elbows, viscosity of pumping fluid, elevation (atmospheric pressure) and pipe friction loss all affect the amount of suction lift your pump will attain.

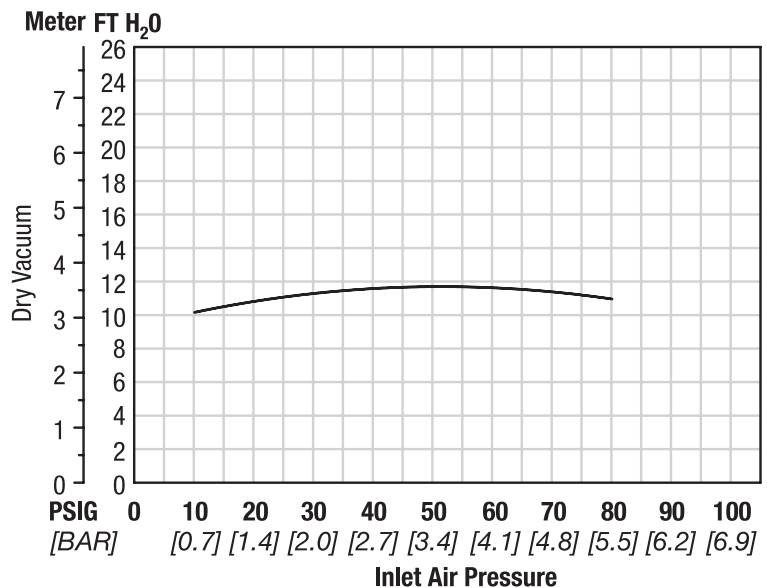



SUGGESTED INSTALLATION

Wilden pumps are designed to meet the performance requirements of even the most demanding pumping applications. They have been designed and manufactured to the highest standards and are available in a variety of liquid-path materials to meet your chemical-resistance needs. Refer to the performance section of this manual for an in-depth analysis of the performance characteristics of your pump. Wilden offers the widest variety of elastomer options in the industry to satisfy temperature, chemical-compatibility, abrasion-resistance and flex concerns.

The suction pipe size should be at least the equivalent or larger than the diameter size of the suction inlet on your Wilden pump. The suction hose must be non-collapsible, reinforced type as these pumps are capable of pulling a high vacuum. Discharge piping should also be the equivalent or larger than the diameter of the pump discharge, which will help reduce friction losses. It is critical that all fittings and connections are airtight or a reduction or loss of pump suction capability will result.

INSTALLATION: Months of careful planning, study and selection efforts can result in unsatisfactory pump performance if installation details are left to chance.

Premature failure and long-term dissatisfaction can be avoided if reasonable care is exercised throughout the installation process.

LOCATION: Noise, safety and other logistical factors usually dictate where equipment will be situated on the production floor. Multiple installations with conflicting requirements can result in congestion of utility areas, leaving few choices for additional pumps.

Within the framework of these and other existing conditions, every pump should be located in such a way that six key factors are balanced against each other to maximum advantage.

ACCESS: First of all, the location should be accessible. If it's easy to reach the pump, maintenance personnel will have an easier time carrying out routine inspections and adjustments. Should major repairs become necessary, ease of access can play a key role in speeding the repair process and reducing total downtime.

AIR SUPPLY: Every pump location should have an air line large enough to supply the volume of air necessary to achieve the desired pumping rate. Use air pressure up to a maximum of 5.9 bar (85 psig) depending on pumping requirements.

For best results, the pumps should use a 5 μ (micron) air filter, needle valve and regulator. The use of an air filter before the pump will ensure that the majority of any pipeline contaminants will be eliminated.

SOLENOID OPERATION: When operation is controlled by a solenoid valve in the air line, three-way valves should be used. This valve allows trapped air between the valve and the pump to bleed off, which improves pump performance. Pumping volume can be estimated by counting the number of strokes per minute and then multiplying the figure by the displacement per stroke.

MUFFLER: Sound levels are reduced below OSHA specifications using the standard Wilden muffler. Other mufflers can be used to further reduce sound levels, but they usually reduce pump performance.

ELEVATION: Selecting a site that is well within the pump's dynamic-lift capability will ensure that loss-of-prime issues will be eliminated. In addition, pump efficiency can be adversely affected if proper attention is not given to site location.

PIPING: Final determination of the pump site should not be made until the piping challenges of each possible location have been evaluated. The impact of current and future installations should be considered ahead of time to make sure that inadvertent restrictions are not created for any remaining sites.

The best choice possible will be a site involving the shortest and straightest hookup of suction and discharge piping. Unnecessary elbows, bends and fittings should be avoided. Pipe sizes should be selected to keep friction losses within practical limits. All piping should be supported independently of the pump. In addition, the piping should be aligned to avoid placing stress on the pump fittings.

Flexible hose can be installed to aid in absorbing the forces created by the natural reciprocating action of the pump. If the pump is to be bolted down to a solid location, a mounting pad placed between the pump and the foundation will assist in minimizing pump vibration. Flexible connections between the pump and rigid piping will also assist in minimizing pump vibration. If quick-closing valves are installed at any point in the discharge system, or if pulsation within a system becomes a problem, a surge suppressor (SD Equalizer®) should be installed to protect the pump, piping and gauges from surges and water hammer.

If the pump is to be used in a self-priming application, make sure that all connections are airtight and that the suction lift is within the model's ability. **NOTE:** Materials of construction and elastomer material have an effect on suction-lift parameters. Please refer to the performance section for specifics.

When pumps are installed in applications involving flooded suction or suction-head pressures, a gate valve should be installed in the suction line to permit closing of the line for pump service.

Pumps in service with a positive suction head are most efficient when inlet pressure is limited to 0.5–0.7 bar (7–10 psig). Premature diaphragm failure may occur if positive suction is 0.7 bar (10 psig) and higher.

ALL WILDEN PUMPS ARE CAPABLE OF PASSING SOLIDS. A STRAINER SHOULD BE USED ON THE PUMP INTAKE TO ENSURE THAT THE PUMP'S RATED SOLIDS CAPACITY IS NOT EXCEEDED.

CAUTION: DO NOT EXCEED 5.9 BAR (85 PSIG) AIR SUPPLY PRESSURE.

SUGGESTED INSTALLATION

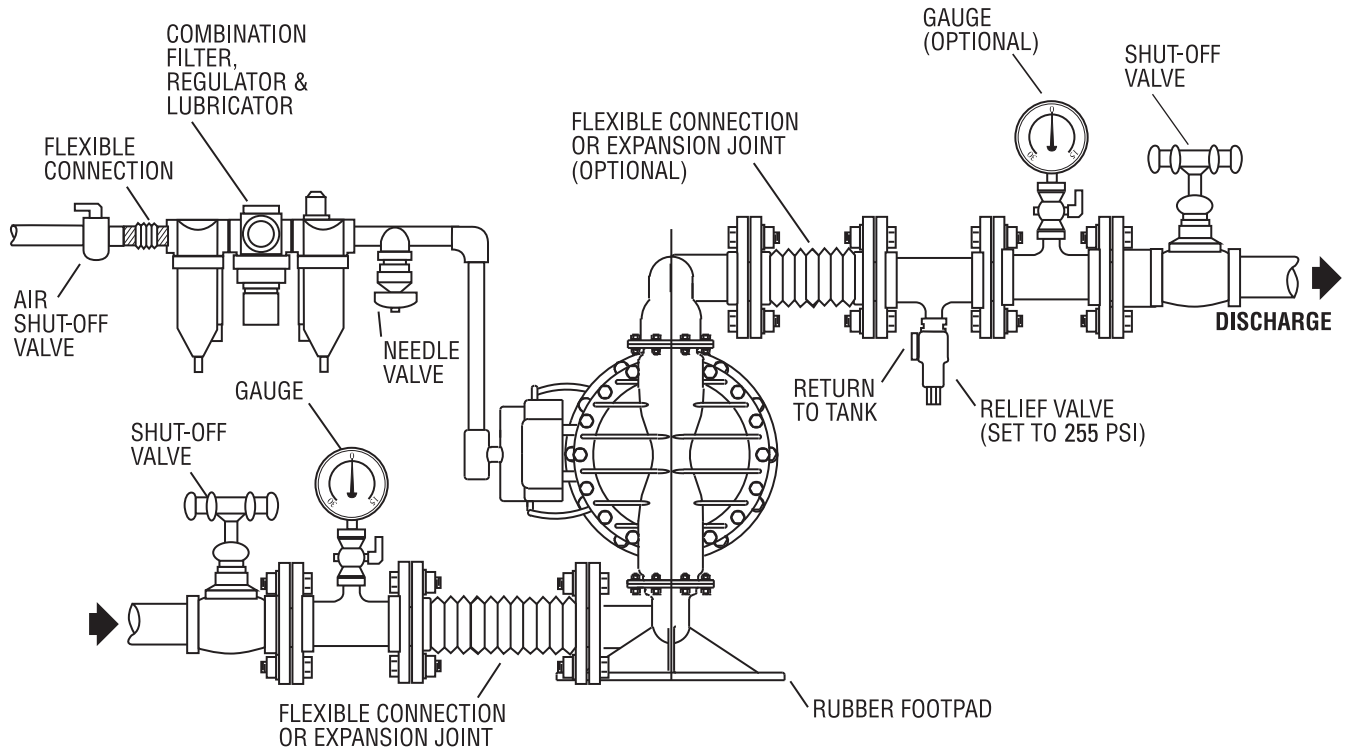

NOTE: In the event of a power failure, the shut-off valve should be closed if the restarting of the pump is not desirable once power is regained.

AIR-OPERATED PUMPS: To stop the pump from operating in an emergency situation, simply close the shut-off valve (user-supplied) installed in the air supply line. A properly functioning valve will stop the air supply to the pump, therefore stopping output. This shut-off valve should be located far enough away from the pumping equipment so that it can be reached safely in an emergency situation.

SUGGESTED OPERATION & MAINTENANCE

OPERATION: Pump-discharge rate can be controlled by limiting the volume and/or pressure of the air supply to the pump. An air regulator is used to regulate air pressure. A needle valve is used to regulate volume. Pump discharge rate can also be controlled by throttling the pump discharge by partially closing a valve in the discharge line of the pump. This action increases friction loss which reduces flow rate. (See Section 5.) This is useful when the need exists to control the pump from a remote location. When the pump discharge pressure equals or exceeds the air supply pressure, the pump will stop; no bypass or pressure relief valve is needed, and pump damage will not occur. The pump has reached a "deadhead" situation and can be restarted by reducing the fluid discharge pressure or increasing the air inlet pressure. The Wilden H800 pump runs solely on compressed air and does not generate heat, therefore your process fluid temperature will not be affected.

MAINTENANCE AND INSPECTIONS: Since each application is unique, maintenance schedules may be different for every pump. Frequency of use, line pressure, viscosity and abrasiveness of process fluid all affect the parts life of a Wilden pump. Periodic inspections have been found to offer the best means for preventing unscheduled pump downtime. Personnel familiar with the pump's construction and service should be informed of any abnormalities that are detected during operation.

RECORDS: When service is required, a record should be made of all necessary repairs and replacements. Over a period of time, such records can become a valuable tool for predicting and preventing future maintenance problems and unscheduled downtime. In addition, accurate records make it possible to identify pumps that are poorly suited to their applications.

TROUBLESHOOTING

Pump will not run or runs slowly.

1. With the use of the flow curve located in the performance section of this EOM, verify air pressure and volume required for your application. If inlet air pressure is too low, the H800 pump will not operate.
2. Check air inlet filter for debris (see SUGGESTED INSTALLATION).
3. Disassemble pump and check for obstructions in the air passageways or objects that would obstruct the movement of internal parts.
4. Check for sticking ball check valves. If material being pumped is not compatible with pump elastomers, swelling may occur. Replace ball check valves and seals with proper elastomers. Also, as the check valve balls wear out, they become smaller and can become stuck in the seats. In this case, replace balls and seats.
5. Inspect pressure relief valve for damage. Replace if necessary with genuine Wilden parts.
6. Inspect the center block seals for damage. Replace if necessary.

Pump runs but little or no product flows.

1. Check for pump cavitation; slow pump speed down to allow thick material to flow into liquid chambers.
2. Verify that vacuum required to lift liquid is not greater than the vapor pressure of the material being pumped (cavitation).

3. Check for sticking ball check valves. If material being pumped is not compatible with pump elastomers, swelling may occur. Replace ball check valves and seats with proper elastomers. Also, as the check valve balls wear out, they become smaller and can become stuck in the seats. In this case, replace balls and seats.
4. Check tightness of inlet and discharge connections.
5. Check tightness of all fasteners.

Pump air valve freezes.

1. Check for excessive moisture in compressed air. Either install a dryer or hot-air generator for compressed air. Alternatively, a coalescing filter may be used to remove the water from the compressed air in some applications.

Air bubbles in pump discharge.

1. Check for ruptured diaphragm.
2. Check tightness of outer pistons (refer to Section 7).
3. Check tightness of fasteners and integrity of O-rings and seals, especially at intake manifold.
4. Ensure pipe connections are airtight.

Product comes out air exhaust.

1. Check for diaphragm rupture.
2. Check tightness of outer pistons to shaft.
3. Check tightness of fasteners that connect the inner piston to the outer piston.

PUMP DISASSEMBLY

Tools Required

- 1/2" Wrench
- 9/16" Wrench
- 5/8" Wrench
- 3/4" Wrench
- 7/8" Wrench
- 1" Wrench
- 5/64" Hex-Head Wrench
- 5/32" Hex-Head Wrench
- 1/4" Hex-Head Wrench
- 5/16" Hex-Head Wrench
- O-Ring Pick
- Adjustable Wrench
- Snap-Ring Pliers

CAUTION: Before any maintenance or repair is attempted, the compressed air line to the pump should be disconnected and all air pressure allowed to bleed from the pump. Disconnect all intake, discharge and air lines. Drain the pump by turning it upside down and allowing any fluid to flow into a suitable container. Be aware of any hazardous effects of contact with your process fluid.

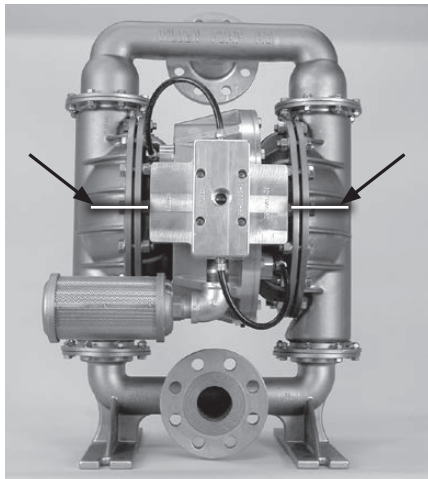
**Step 1**

Put alignment marks on liquid chambers and air chambers. Use to properly align center section with liquid chamber during reassembly.

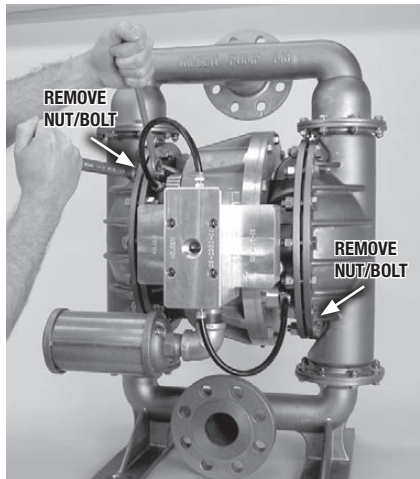
**Step 2**

Using a 3/4" wrench, remove liquid chamber fasteners adjacent to relief valves.

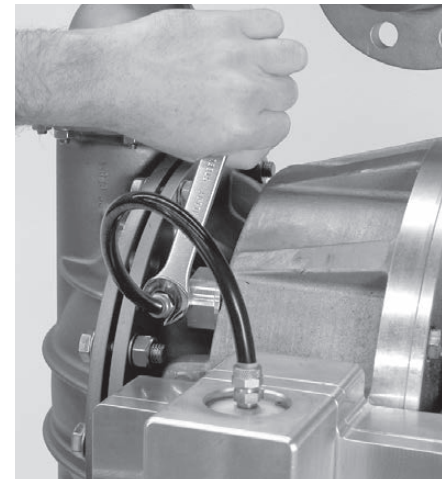
**Step 3**

Using a 9/16" wrench, loosen tubing nuts located by each pressure relief valve.

PUMP DISASSEMBLY

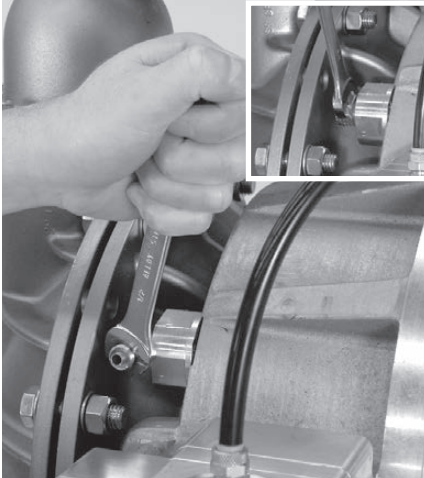

Step 4

Using a 1/2" wrench, loosen pipe fitting and elbow. This will allow easy access to the relief valve.

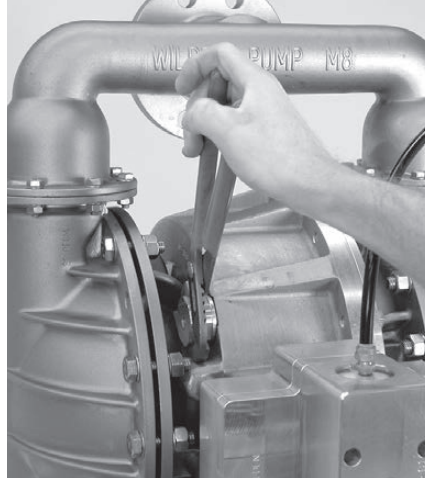

Step 5

Using an adjustable wrench, remove each pressure relief valve.



Step 6

Using a 5/64" hex-head wrench, remove the four fasteners to disassemble the pressure relief valve.



Step 7

Inspect for nicks, gouges, chemical attack or abrasive wear and reassemble when complete. Replace if necessary with genuine Wilden parts. **NOTE:** Pressure relief valves are sold as an assembly only.

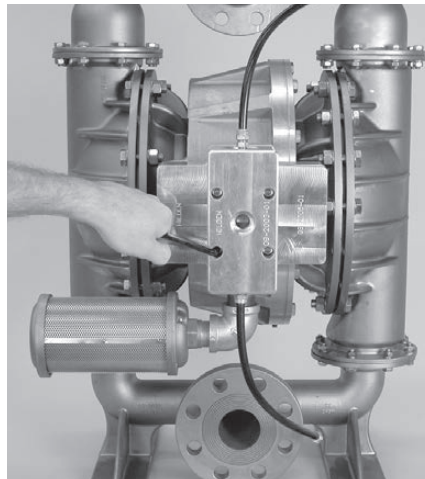

Step 8

Using a 1/4" hex-head wrench, remove the fasteners that connect the air valve and air valve gasket to the center section and lift air valve and isolator cover away from pump.

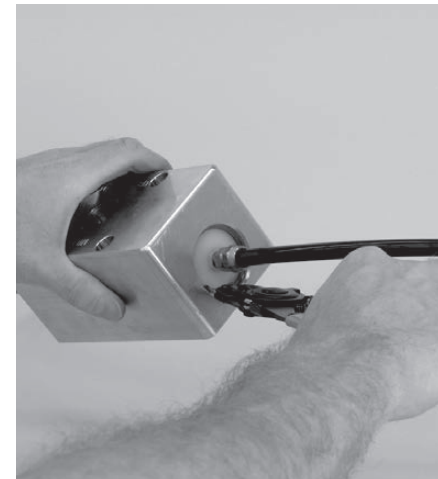

Step 9

Using a pair of snap-ring pliers, remove the top snap-ring from the air valve body.

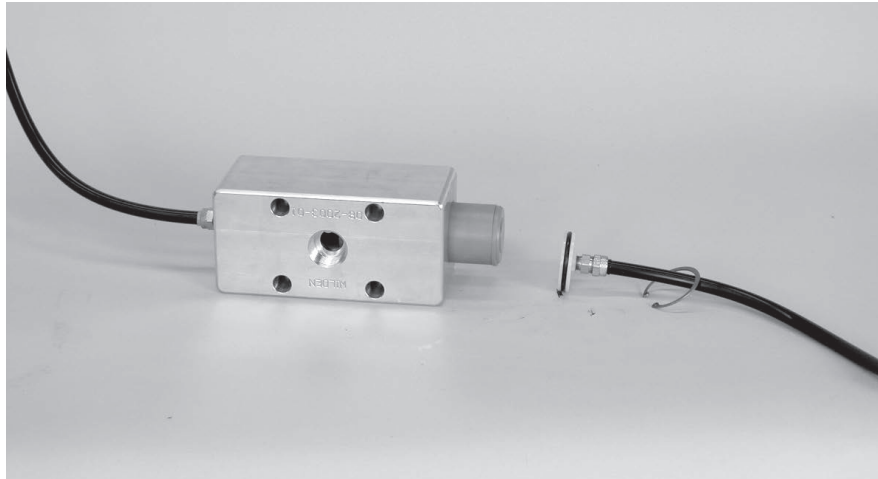

Step 10

Inspect air piston, air valve body and air valve end cap (including air valve O-ring) for nicks, gouges, chemical attack or abrasive wear. Replace if necessary with genuine Wilden parts.

Hints & Tips – Using an air nozzle, alternately pressurize top and bottom bleeder holes until the top end cap is forced from air valve body.

CAUTION: End cap may come out with considerable force. Position a shop rag or equivalent over the top end cap to ensure that the end cap doesn't harm the pump technician or anyone else in the immediate area of the pump.

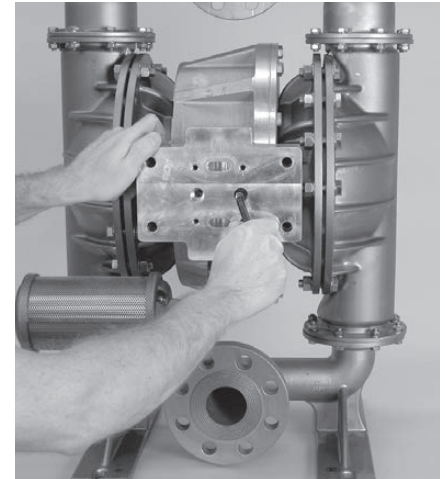

Step 11

Using a 5/16" hex-head wrench, remove the two air valve manifold fasteners.

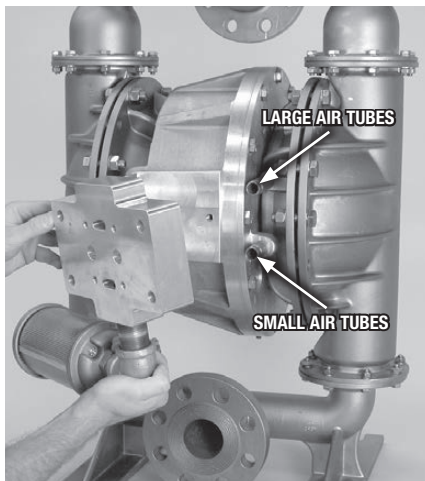

Step 12

Located behind the air valve manifold are four tubes (two small and two larger) sealed by O-rings. Remove all four tubes from pump.

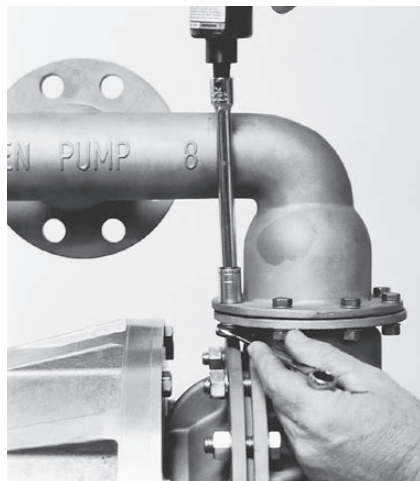

Step 13

Using a 1/2" wrench and socket, remove discharge manifold fasteners.

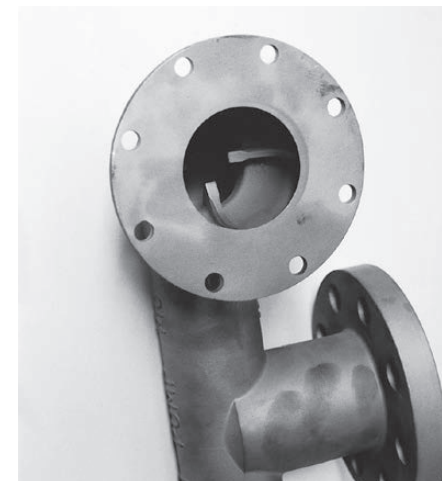

Step 14

After removing discharge manifold, inspect for abrasion in the ball cage area.

PUMP DISASSEMBLY

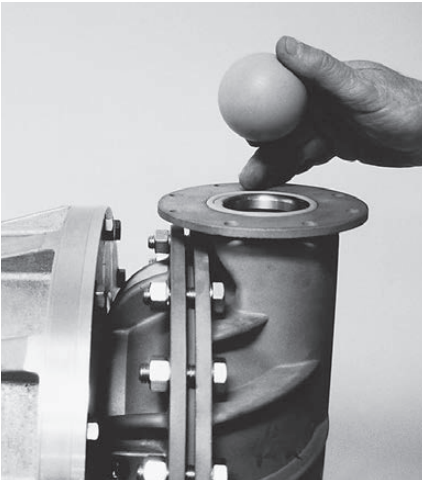

Step 15

Remove valve ball, valve seat and valve seat O-ring from liquid chamber and inspect.

Hints & Tips – When reinstalling the valve seat, position valve seat square side up.

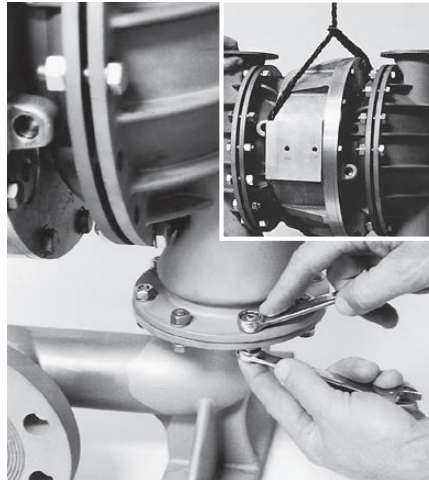

Step 16

Prior to disconnecting the inlet manifold from the liquid chambers, secure the center assembly with the use of a crane or fork lift with straps. To secure the center assembly, wrap the straps around the air cylinder. Using two 1/2" wrenches, remove the inlet manifold fasteners.

CAUTION: The center assembly is very heavy and could injure the pump technician or anyone in the immediate area if the center assembly were to fall from the inlet manifold.

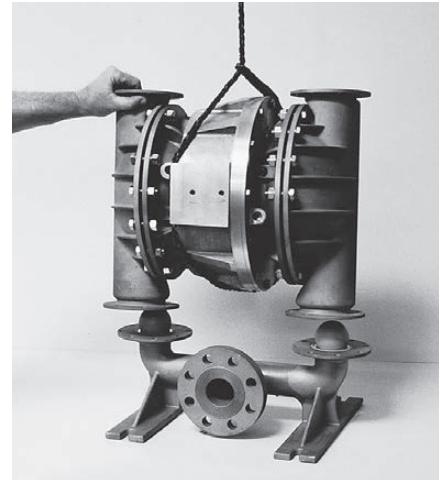

Step 17

Hints & Tips - With the center assembly suspended, remove the fasteners to connect the liquid chambers to the air chambers.



Step 18

With the liquid chambers removed and using extreme caution, lower the power cylinder and air chambers to a sturdy flat surface and position on the flat side of the power cylinder.

AIR VALVE / CENTER-SECTION DISASSEMBLY

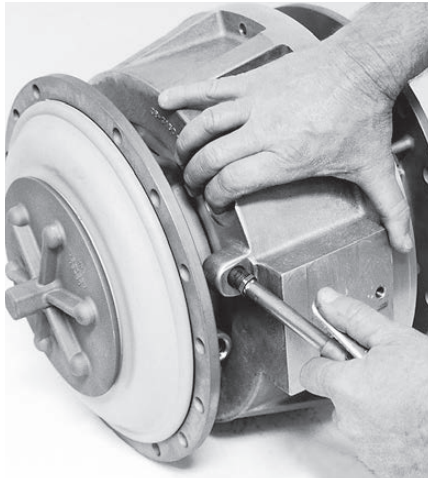

Step 1

Rotate power cylinder so that the front (flat) of the power cylinder is accessible. Using an air nozzle with a rubber tip and placing a suitable object over the pressure relief valve port, pressurize air tube port. This will cause the diaphragm assembly to move to one side for ease of disassembly.

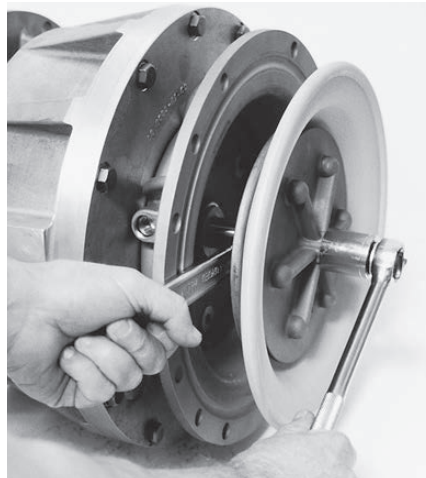

Step 2

Using a 7/8" open-end wrench placed on the flat of the diaphragm shaft, and a 1" wrench placed on the outer piston lug, remove the diaphragm assembly by turning counterclockwise.



Step 3

Using a 5/16" hex-head wrench, remove the fasteners that connect the inner piston to the diaphragm assembly. Inspect diaphragm for nicks, gouges, chemical attack or abrasion. Replace if necessary with genuine Wilden parts.

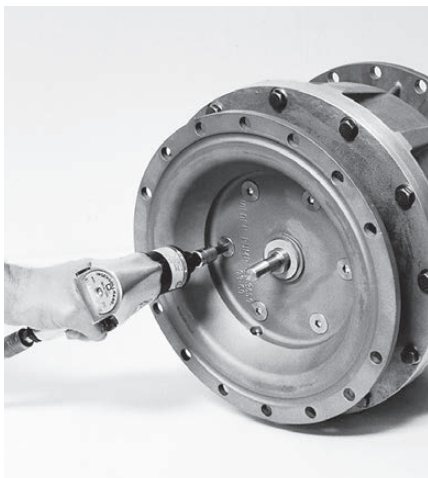

Step 4

Using a 5/16" hex-head wrench, remove the air chamber fasteners.

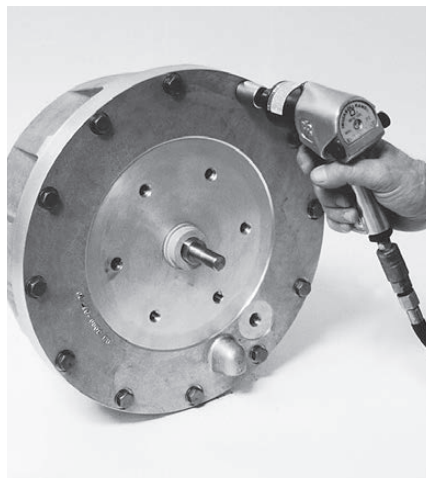

Step 5

Using a 5/8" wrench, remove the fasteners that connect the power cylinder cover to the power cylinder body.



Step 6

Using an air nozzle with a rubber tip, apply air to the relief valve port. This will force the power cylinder cover away from the power cylinder body. Inspect shaft bushing seals and O-ring on power cylinder cover for damage.

AIR VALVE / CENTER-SECTION DISASSEMBLY

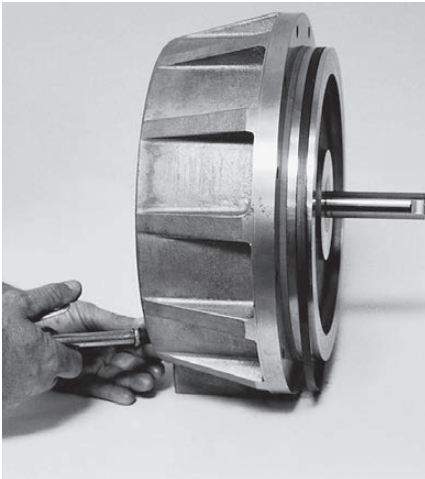

Step 7

Continue to apply air pressure to the relief valve port until the power cylinder piston is moved out of the power cylinder body.

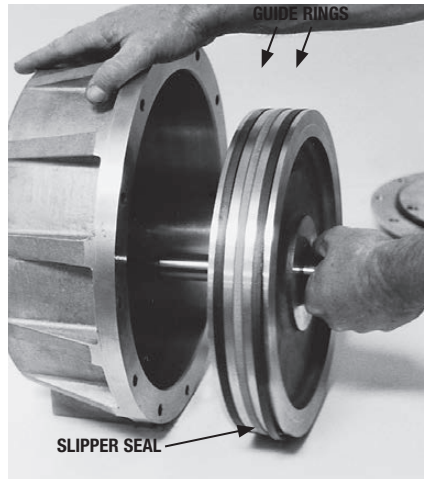

Step 8

Using one hand and steadying the power cylinder body with the other, remove power cylinder piston. Inspect the slipper seal and guide rings located on the power piston for damage.

POWER CYLINDER REASSEMBLY

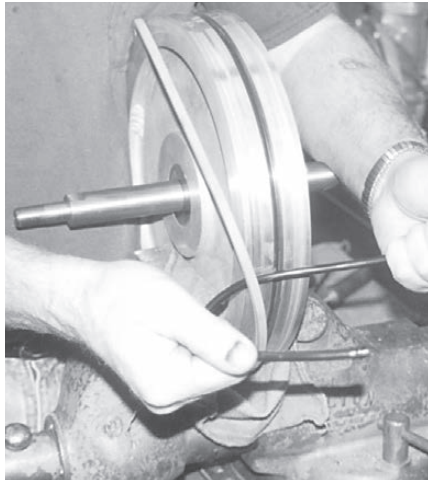

Step 1

After attaching the diaphragm shaft and bushing to the power cylinder piston, place power cylinder piston in vice with soft jaws (do not damage piston). Next, install new slipper seal.

Hints & Tips – Using a strip of material (like an old O-ring), slide the material back and forth until the slipper seal is positioned above the center groove.



Step 2

Next, place the power cylinder and power cylinder piston on top of two blocks of wood or equivalent.

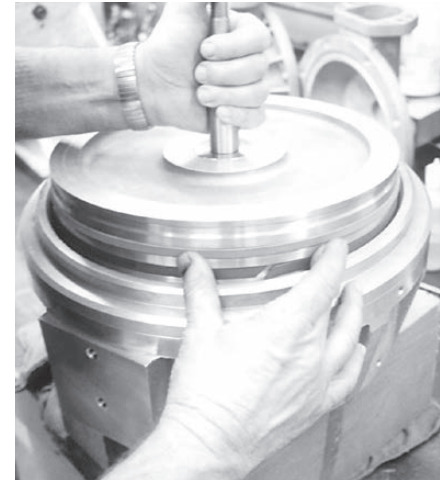

Step 3

Insert new guide rings in outer grooves. Very easily, begin to maneuver the power cylinder piston into the power cylinder body.

Hints & Tips – A conical (tapered) piece of cylindrical sheet material or equivalent can be used to hold the guide rings in place as the power cylinder piston slides into the power cylinder body.



Step 4

Using a rubber mallet, lightly tap power cylinder piston in a circular fashion until piston is maneuvered completely into power cylinder body. When performing this task, use caution to not damage the guide rings or slipper seal.

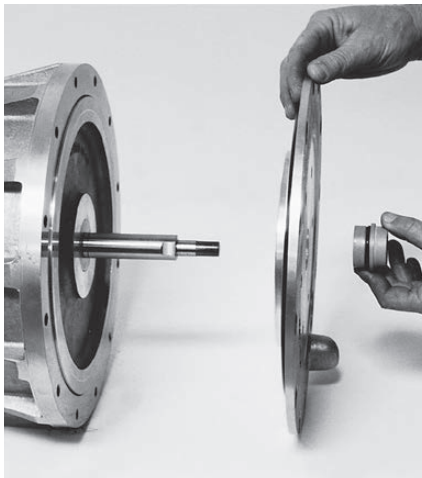

Step 5

As a last step install power cylinder cover to power cylinder body and secure with fasteners provided.

REASSEMBLY HINTS & TIPS

ASSEMBLY:

Upon performing applicable maintenance to the air distribution system, the pump can now be reassembled. Please refer to the disassembly instructions for photos and parts placement. To reassemble the pump, follow the disassembly instructions in reverse order. The air distribution system needs to be assembled first, then the diaphragms and finally the wetted path. Please find the applicable torque specifications on this page. The following tips will assist in the assembly process.

- Lubricate air valve bore, center section shaft and pilot spool bore with NLGI grade 2 white EP bearing grease or equivalent.
- Clean the inside of the center section shaft bore to ensure no damage is done to new seals.
- A small amount of NLGI grade 2 white EP bearing grease can be applied to the muffler and air valve gaskets to lubricate gaskets during assembly.
- Make sure that the exhaust port on the muffler plate is centered between the two exhaust ports on the center section.
- Stainless-steel bolts should be lubed to reduce the possibility of seizing during tightening.

MAXIMUM TORQUE SPECIFICATIONS

Part Description	H800 Stainless Steel	H800 Ductile Iron
Inner Piston Screws*	58.3 N•m (43 ft-lb)	58.3 N•m (43 ft-lb)
Outer Piston	140 N•m (103 ft-lb)	140 N•m (103 ft-lb)
Air Valve Bolts	9.5 N•m (84.1 in-lb)	9.5 N•m (84.1 in-lb)
Inlet/Discharge Manifold Bolts	17.6 N•m (13 ft-lb)	163 N•m (120 ft-lb)
Center Section Cover Bolts	54.0 N•m (40 ft-lb)	54.0 N•m (40 ft-lb)
Air Chamber Screws*	88.1 N•m (65 ft-lb)	163 N•m (120 ft-lb)
Liquid Chamber Bolts	58.3 N•m (43 ft-lb)	163 N•m (120 ft-lb)

*Use #242 removable Loctite® on fastener threads.

Torque all hardware in an opposing torque sequence. Liquid chamber bolts may require periodic retightening. If liquid chamber pre-load torque values fall below: [stainless steel 33.9 N•m (25 ft-lb); ductile iron 108 N•m (80 ft-lb)] retighten both liquid chambers to a maximum of: [stainless steel 58.3 N•m (43 ft-lb); ductile iron 163 N•m (120 ft-lb)]. Liquid chamber torque loading must be even. If any of the liquid chamber bolts require retightening, it is suggested that all liquid chamber bolts be retightened to ensure even distribution.

Figure A

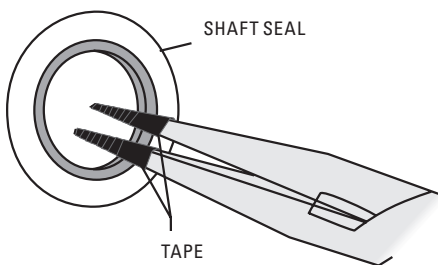

BUSHING SEAL INSTALLATION:

PRE-INSTALLATION

- Once all of the old seals have been removed, the inside of the bushing should be cleaned to ensure no debris is left that may cause premature damage to the new seals.

INSTALLATION

The following tools can be used to aid in the installation of the new seals:

- Needle-Nose Pliers
- Phillips Screwdriver
- Electrical Tape

- Wrap electrical tape around each leg of the needle-nose pliers (heat shrink tubing may also be used). This is done to prevent damaging the inside surface of the new seal.
- With a new seal in hand, place the two legs of the needle-nose pliers inside the seal ring. (See Figure A.)
- Open the pliers as wide as the seal diameter will allow, then with two fingers pull down on the top portion of the seal to form kidney shape. (See Figure B.)
- Lightly clamp the pliers together to hold the seal into the kidney shape. Be sure to pull the seal into as tight of a kidney shape as possible, this will allow the seal to travel down the bushing bore easier.
- With the seal clamped in the pliers, insert the seal into the bushing bore and position the bottom of the seal into the bushing groove. Once the bottom of the seal is seated in the groove, release the clamp pressure on the pliers. This will allow the seal to partially snap back to its original shape.
- After the pliers are removed, you will notice a slight bump in the seal shape. Before the seal can be properly resized, the bump in the seal should be removed as much as possible. This can be done with either the Phillips screwdriver or your finger. With either the side of the screwdriver or your finger, apply light pressure to the peak of the bump. This pressure will cause the bump to be almost completely eliminated.
- Lubricate the edge of the shaft with NLGI grade 2 white EP bearing grease.
- Slowly insert the center shaft with a rotating motion. This will complete the resizing of the seal.
- Perform these steps for the remaining seals.

Figure B

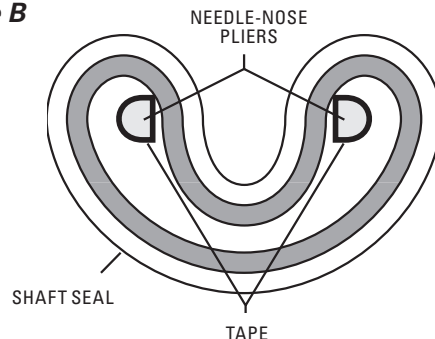

NOTES

EXPLODED VIEW & PARTS LISTING

H800 DUCTILE IRON

EXPLODED VIEW

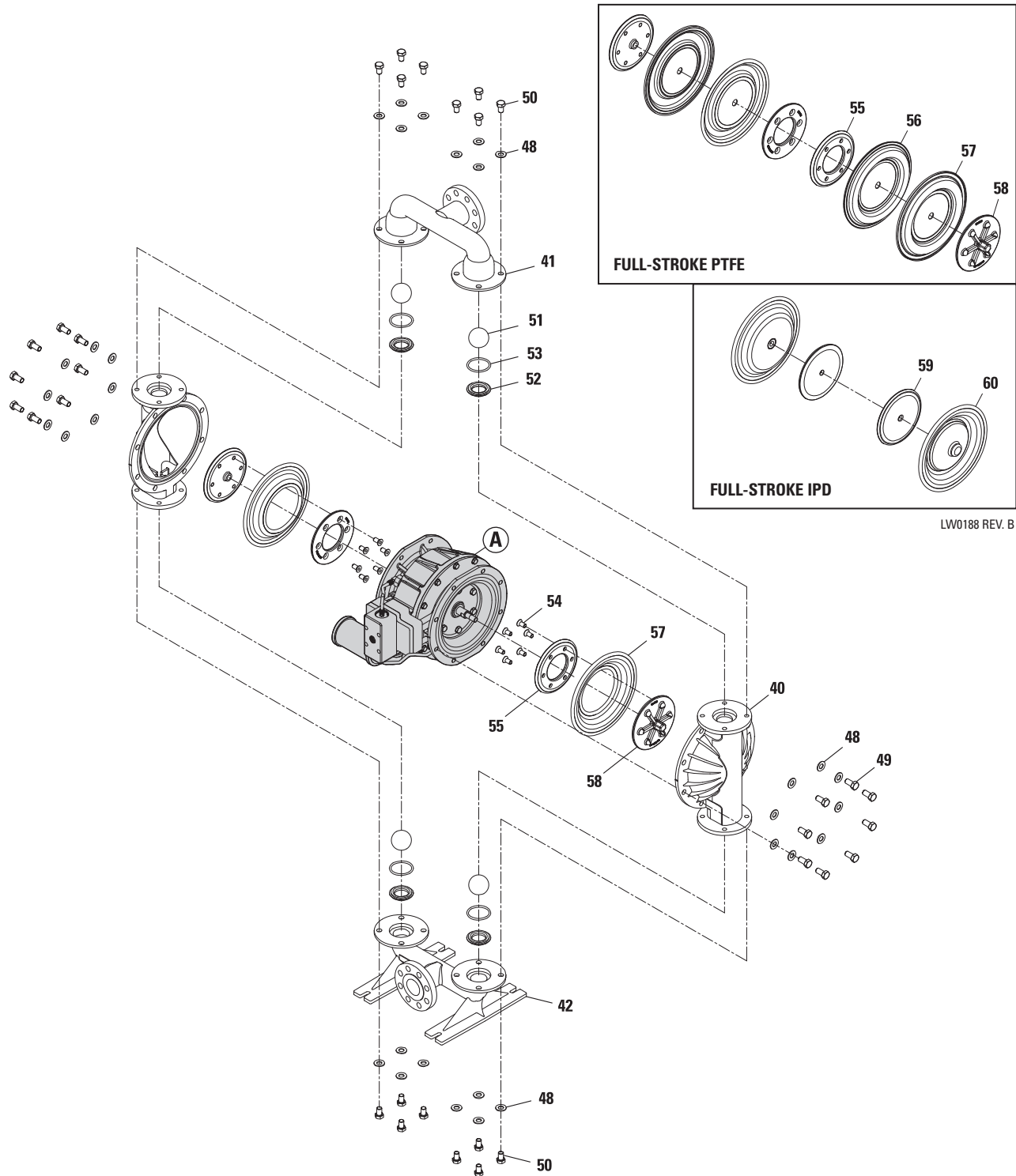

EXPLODED VIEW & PARTS LISTING

H800 STAINLESS STEEL

EXPLODED VIEW

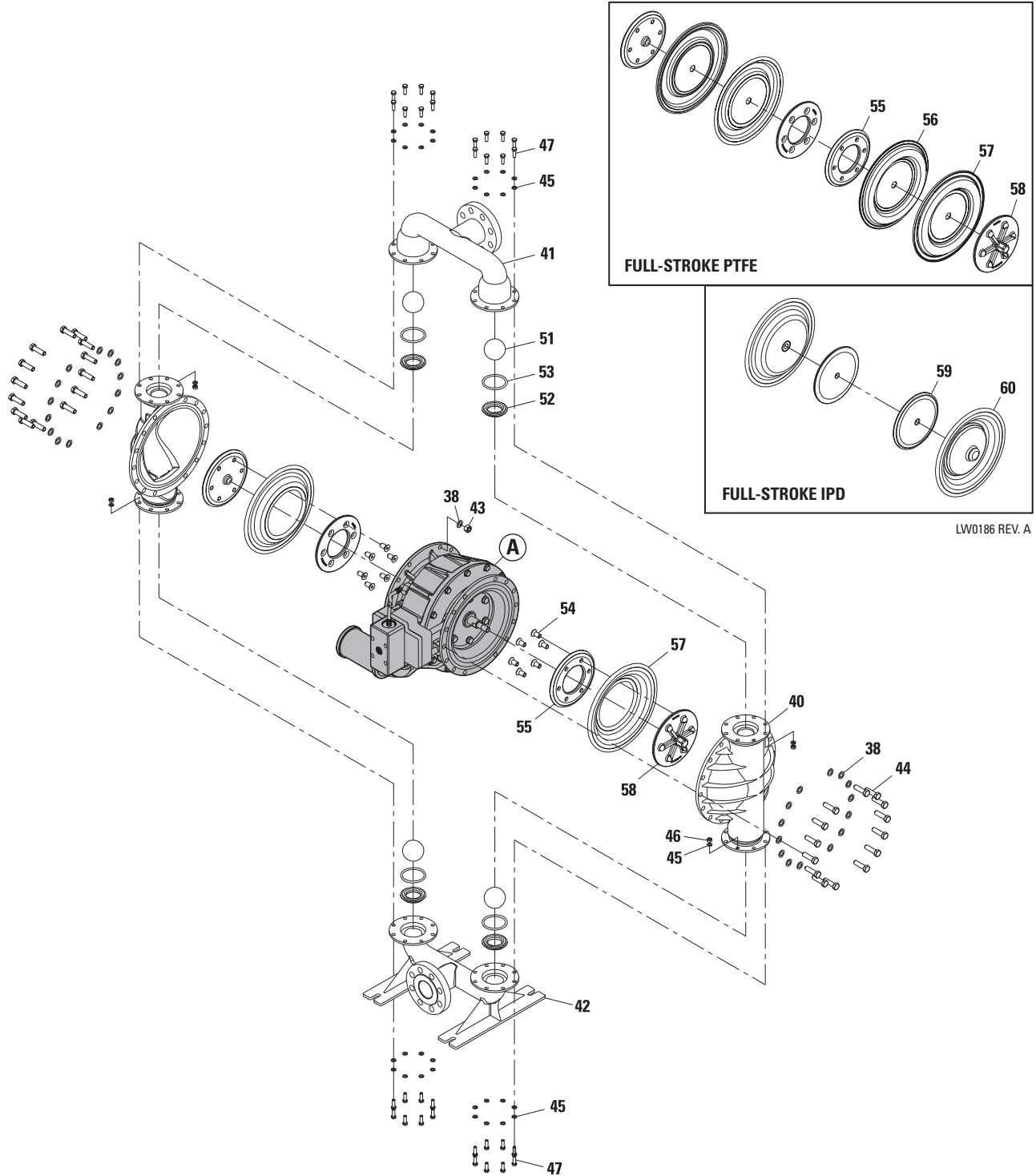

LW0186 REV. A

EXPLODED VIEW & PARTS LISTING

H800 METAL

CENTER SECTION

EXPLODED VIEW

DRAWING A

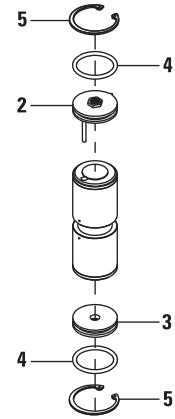
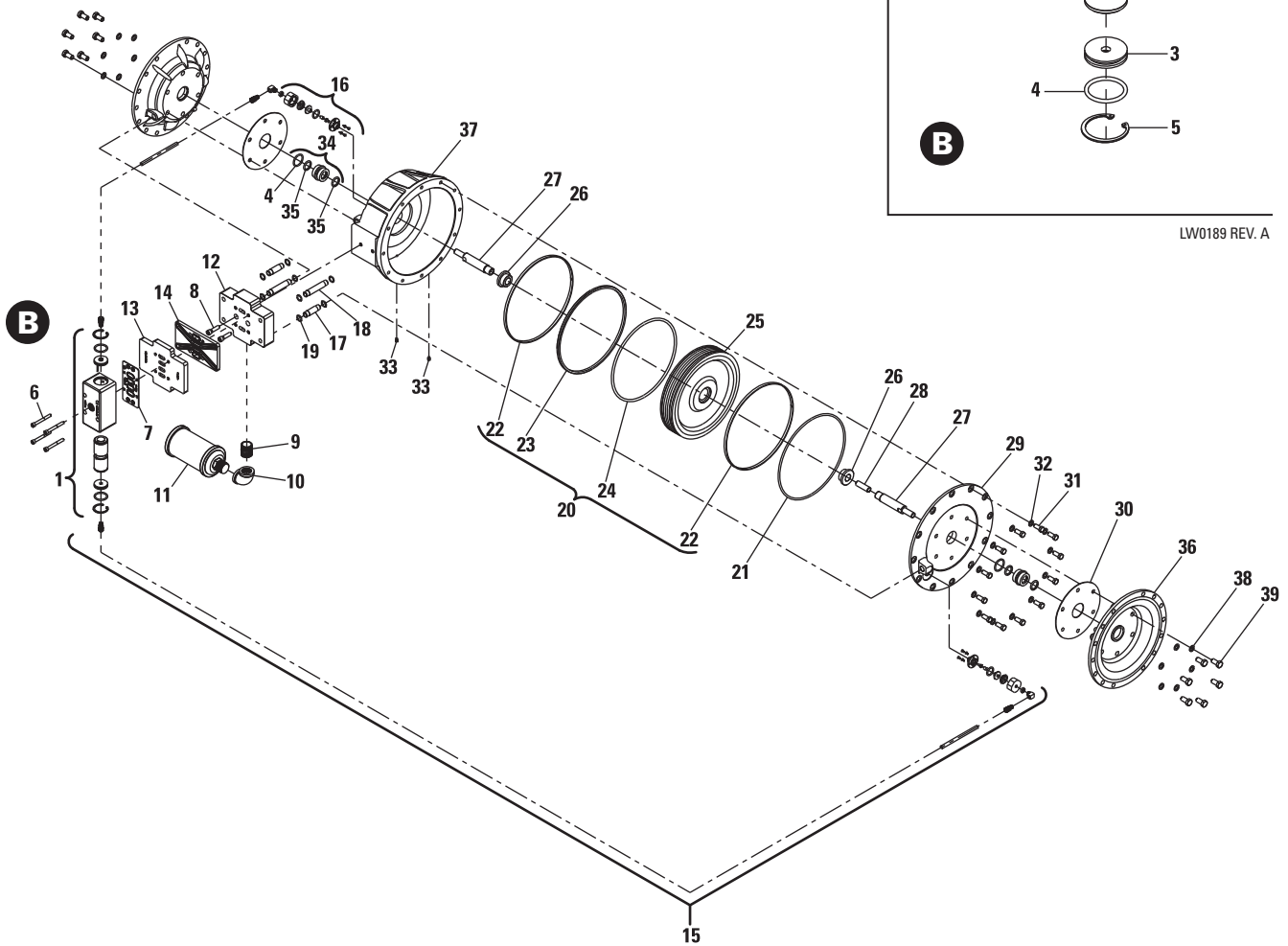

LW0189 REV. A

EXPLODED VIEW & PARTS LISTING

H800 METAL

PARTS LISTING

Item	Part Description	Qty.	H800/WWWAA/...P/N	H800/SSAA/...P/N	H800/HHSA/...P/N
AIR DISTRIBUTION COMPONENTS					
1	Air Valve Assembly¹	1	08-2003-01	08-2003-01	08-2003-01
2	End Cap w/Guide Nylon	1	08-2306-23	08-2306-23	08-2306-23
3	End Cap w/o Guide Nylon	1	08-2336-23	08-2336-23	08-2336-23
4	O-Ring (-220) (Ø1.359 x Ø.139)	2	15-2390-52	15-2390-52	15-2390-52
5	Retaining Ring	2	15-2650-03	15-2650-03	15-2650-03
6	Screw, SHC, Air Valve (5/16"-18 x 2-3/4")	4	08-6000-03-83	08-6000-03-83	08-6000-03-83
7	Air Valve Gasket	1	08-2601-52	08-2601-52	08-2601-52
8	Screw, SHC, Manifold (3/8"-16 x 1-1/2")	2	99-6034-08	99-6034-08	99-6034-08
9	Nipple, 1" NPT, Galvanized	1	08-7430-08-60	08-7430-08-60	08-7430-08-60
10	Elbow, 90°, 1" NPT, Galvanized	1	08-7840-08-60	08-7840-08-60	08-7840-08-60
11	Muffler	1	15-3510-99	15-3510-99	15-3510-99
12	Manifold, Bottom Air Valve	1	08-2700-01	08-2700-01	08-2700-01
13	Plate, Isolator Cover	1	08-2705-01	08-2705-01	08-2705-01
14	Gasket, Air Valve Isolator	1	08-2603-52	08-2603-52	08-2603-52
15	Relief Tube Assembly	2	08-9232-99-60	08-9232-99-60	08-9232-99-60
16	Pressure Relief Valve Assembly	2	08-2740-99-60	08-2740-99-60	08-2740-99-60
	Rebuild Pressure Relief Seal Kit	1	99-9346-99	99-9346-99	99-9346-99
17	Pipe	2	08-7520-03-60	08-7520-03-60	08-7520-03-60
18	Pipe	2	08-7510-03-60	08-7510-03-60	08-7510-03-60
19	O-Ring (-114) Pipe (Ø.612 x Ø.103)	8	00-2870-52	00-2870-52	00-2870-52
20	Power Piston Seal Kit ²	1	08-9210-99-60	08-9210-99-60	08-9210-99-60
21	O-Ring (-379) Cover (Ø10.975 x Ø.210)	1	-	-	-
22	Guide Ring, Bronze-Filled	2	-	-	-
23	Slipper Seal, PTFE-Filled	1	-	-	-
24	O-Ring (-450) Piston (Ø10.475 x Ø.275)	1	-	-	-
25	Piston, Cylinder	1	08-3720-01-60	08-3720-01-60	08-3720-01-60
26	Bushing, Cylinder Piston	2	08-3730-03-60	08-3730-03-60	08-3730-03-60
27	Shaft	2	08-3800-03-60	08-3800-03-60	08-3800-03-60
28	Stud, Shaft	1	08-6150-08-60	08-6150-08-60	08-6150-08-60
29	Cover, Center Section	1	08-3000-01-60	08-3000-01-60	08-3000-01-60
30	Gasket, Center Section	2	08-3260-52-60	08-3260-52-60	08-3260-52-60
31	Screw, HHC (7/16"-14 x 1")	12	08-6260-08-60	08-6260-08-60	08-6260-08-60
32	Washer (7/16")	12	08-6830-03-60	08-6830-03-60	08-6830-03-60
33	Pipe Plug, 1/16" NPT	2	08-7030-08-60	08-7030-08-60	08-7030-08-60
34	Bushing, Assembly Center Section ³	2	08-3300-99-60	08-3300-99-60	08-3300-99-60
35	Glyd Ring	4	15-3210-55-225	15-3210-55-225	15-3210-55-225
	O-Ring (-220) (Ø1.359 x Ø.139) Item No. 4	2	15-2390-52	15-2390-52	15-2390-52
36	Chamber, Air	2	08-3653-02-60	08-3653-03-60	08-3653-03-60
37	Section, Center	1	08-3150-01-60	08-3150-01-60	08-3150-01-60
38	Washer (1/2")	12	08-6840-03-60	08-6840-03-60	08-6840-03-60
39	Screw, HHC (1/2"-13 x 1")	12	08-6132-08	08-6132-08	08-6132-08
WETTED PATH COMPONENTS					
40	Liquid Chamber	2	08-5000-02-60	08-5000-03-60	08-5000-04-60
41	Discharge Manifold (ANSI)	1	08-5020-02-62	08-5020-03-62	08-5020-04-62
	Discharge Manifold (DIN)	1	08-5020-02-63	08-5020-03-63	08-5020-04-63
42	Inlet Manifold (ANSI)	1	08-5080-02-62	08-5080-03-62	08-5080-04-62
	Inlet Manifold (DIN)	1	08-5080-02-63	08-5080-03-63	08-5080-04-63
43	Hex Nut, (1/2"-13)	28	N/A	15-6420-03	15-6420-03
44	Screw, HHC (1/2"-13 x 1-3/4")	28	N/A	08-6190-08-60	08-6190-08-60
38	Washer (1/2")	56	N/A	08-6840-03-60	08-6840-03-60
45	Washer (5/16")	64	N/A	08-6730-03-42	08-6730-03-42
46	Hex Nut, (5/16"-18)	32	N/A	08-6400-03	08-6400-03
47	Screw, HHC (5/16"-18 x 1")	32	N/A	08-6180-03-42	08-6180-03-42
48	Washer (5/8")	32	15-6732-08	N/A	N/A
49	Screw, HHC (5/8"-11 x 1-1/4")	16	15-6193-08	N/A	N/A
50	Screw, HHC (5/8"-11 x 1")	16	08-6187-08	N/A	N/A
VALVE BALLS/VALVE SEATS/VALVE O-RINGS					
51	Ball, Valve	4	*	*	*
52	Seat, Valve	4	08-1120-08-60	08-1120-03-60	08-1120-04-60
53	O-Ring, Seat	4	*	*	*
FULL-STROKE TPE/PTFE COMPONENTS					
54	Screw, SFCHC (1/2"-13 x 1")	12	08-6220-03-60	08-6220-03-60	08-6220-03-60
55	Inner Piston	2	08-3702-02	08-3702-03	08-3702-03
56	Diaphragm, Full-Stroke PTFE, Backup	2	*	*	*
57	Diaphragm, Primary	2	*	*	*
	Diaphragm, Full-Stroke PTFE, Primary	2	*	*	*
58	Outer Piston	2	08-4565-02	08-4565-03	08-4565-04
FULL-STROKE IPD COMPONENTS					
59	Inner Piston	2	08-3700-03	08-3700-03	08-3700-03
60	Diaphragm, Full-Stroke IPD, Primary	2	*	*	*

*Refer to Elastomer Chart

¹Air Valve Assembly includes item numbers 2, 3, 4, and 5.

²Power Piston Seal Kit includes item numbers 21, 22, 23, and 24.

³Bushing Assembly, Center Section, includes qty. 1 of item numbers 34 and 4.

All boldface items are primary wear parts.

0504 Specialty Code = DIN Flange



ELASTOMER OPTIONS

H800 Metal

MATERIAL	DIAPHRAGMS (Color Code)	FULL-STROKE DIAPHRAGMS (Color Code)	FULL-STROKE BACKUP DIAPHRAGMS (Color Code)	FULL-STROKE IPD DIAPHRAGMS (Color Code)	VALVE BALLS (Color Code)	VALVE SEAT O-RINGS (Color Code)
PTFE	N/A	08-1011-55 (white)	N/A	N/A	08-1080-55 (white)	08-1200-55 (white)
FDA WIL-FLEX™	08-1011-57 (2 orange dots)	N/A	08-1067-57 (2 orange dots)	08-1032-57 (2 orange dots)	08-1080-57 (2 orange dots)	N/A
WIL-FLEX™	N/A	N/A	N/A	08-1032-58 (1 orange dot)	08-1080-58 (1 orange dot)	08-1200-58 (cream)

LW0187 REV. C

NOTES

NOTES

WARRANTY

Each and every product manufactured by Wilden Pump and Engineering, LLC is built to meet the highest standards of quality. Every pump is functionally tested to insure integrity of operation.

Wilden Pump and Engineering, LLC warrants that pumps, accessories and parts manufactured or supplied by it to be free from defects in material and workmanship for a period of five (5) years from date of installation or six (6) years from date of manufacture, whichever comes first. Failure due to normal wear, misapplication, or abuse is, of course, excluded from this warranty.

Since the use of Wilden pumps and parts is beyond our control, we cannot guarantee the suitability of any pump or part for a particular application and Wilden Pump and Engineering, LLC shall not be liable for any consequential damage or expense arising from the use or misuse of its products on any application. Responsibility is limited solely to replacement or repair of defective Wilden pumps and parts.

All decisions as to the cause of failure are the sole determination of Wilden Pump and Engineering, LLC.

Prior approval must be obtained from Wilden for return of any items for warranty consideration and must be accompanied by the appropriate MSDS for the product(s) involved. A Return Goods Tag, obtained from an authorized Wilden distributor, must be included with the items which must be shipped freight prepaid.

The foregoing warranty is exclusive and in lieu of all other warranties expressed or implied (whether written or oral) including all implied warranties of merchantability and fitness for any particular purpose. No distributor or other person is authorized to assume any liability or obligation for Wilden Pump and Engineering, LLC other than expressly provided herein.

PLEASE PRINT OR TYPE AND FAX TO WILDEN

PUMP INFORMATION			
Item # _____		Serial # _____	
Company Where Purchased _____			
YOUR INFORMATION			
Company Name _____			
Industry _____			
Name _____		Title _____	
Street Address _____			
City _____	State _____	Postal Code _____	Country _____
Telephone _____	Fax _____	E-mail _____	Web Address _____
Number of pumps in facility? _____		Number of Wilden pumps? _____	
Types of pumps in facility (check all that apply): <input type="checkbox"/> Diaphragm <input type="checkbox"/> Centrifugal <input type="checkbox"/> Gear <input type="checkbox"/> Submersible <input type="checkbox"/> Lobe			
<input type="checkbox"/> Other _____			
Media being pumped? _____			
How did you hear of Wilden Pump? <input type="checkbox"/> Trade Journal <input type="checkbox"/> Trade Show <input type="checkbox"/> Internet/E-mail <input type="checkbox"/> Distributor		<input type="checkbox"/> Other _____	

ONCE COMPLETE, FAX TO (909) 783-3440

OR GO TO PSGDOVER.COM > WILDEN > SUPPORT TO COMPLETE THE WARRANTY REGISTRATION ONLINE

NOTE: WARRANTY VOID IF PAGE IS NOT FAXED TO WILDEN OR SUBMITTED ONLINE VIA THE PSGDOVER.COM WEBSITE

WILDEN PUMP & ENGINEERING, LLC

Where Innovation Flows



WILDEN[®]

PSG

22069 Van Buren St., Grand Terrace, CA 92313-5607

P: +1 (909) 422-1730 • F: +1 (909) 783-3440

wildenpump.com

PSG reserves the right to modify the information and illustrations contained in this document without prior notice. This is a non-contractual document. 11-2018

Authorized PSG Representative:

Copyright ©2018, PSG, A Dover Company