

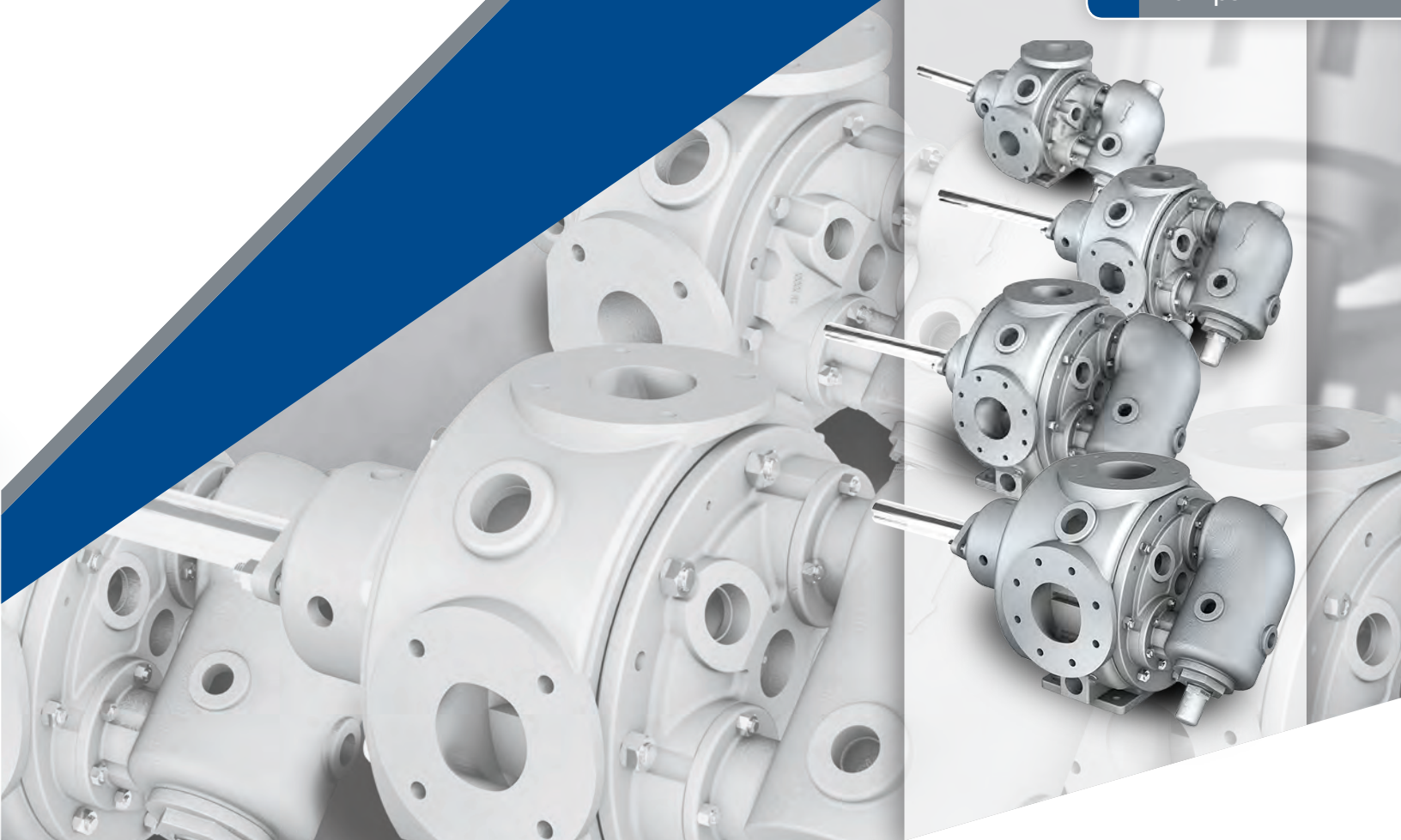

V Series  
Internal Gear  
Pumps



Where Innovation Flows

[envirogearpump.com](http://envirogearpump.com)



**EnviroGear®**, a product brand of PSG®, a Dover company, is a global provider of innovative, high-quality industrial gear pumps for the safe and efficient transfer of high-value and hard-to-seal fluids.

The latest innovation to the EnviroGear product line is a true advancement in the handling of asphaltic products: the V Series Internal Gear Pump. V Series pumps offer numerous features that enable them to overcome the many challenges inherent in the production and handling of asphalt and bitumen products. The main challenge in these operations is the most obvious one: as asphalt changes temperature it can range from a solid to a liquid with a wide variety of fluid characteristics depending on the chemical makeup, which makes it extremely difficult to pump with standard pumping technology. But luckily for those involved, the V Series isn't your standard pump.

A truly exciting development for the industry, V Series pumps address and overcome these hurdles, and do it in a way that is safe, reliable and economical, while also being a direct drop-in replacement for competitive models.

## World-Class Manufacturing Facility

- **Supply Chain:** Every component that goes into an EnviroGear pump is put through a rigid Production Part Approval Process (PPAP) that ensures quality and reliability.
- **Quality Manufacturing:** 100% of EnviroGear pumps are tested for flow, pressure and power before leaving the factory. The facilities are ISO 9001/14001-compliant and feature state-of-the-art coordinate-measuring machines and 3D-scanning equipment that ensure the highest level of part quality.
- **Testing Capabilities:** The R&D and testing laboratory is compliant to Hydraulic Institute 3.6 standards, providing certified performance, NPSH and hydrostatic testing.
- **Global Support:** A full-service global distribution network is ready to serve new or existing EnviroGear pump installations and is backed by responsive factory support.

## Industry Leading Customer Service and Factory Support



5-Year Limited Warranty



15-Day Factory Lead Time for Pumps

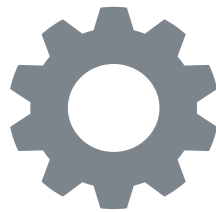

5-Day Factory Lead Time for Parts



Competitive Prices



TR CU-Compliant

## Asphalt and Bitumen Applications

Unlike competitive pumps that are just “good enough” to get the job done, EnviroGear V Series Internal Gear Pumps feature targeted design enhancements that make them ideal for the challenges inherent in the handling and transfer of asphalt and bitumen products.

These design enhancements include:

- Up to 35% more jacket surface area than the competition, which improves system reliability by incorporating the following features:
  - The unique ability to utilize the jacketed head and pressure relief valve (PRV) simultaneously
  - Jacketing located behind the pump rotor, which removes a known cold spot that can result in hard startups and premature pump and seal failures
- The industry's largest jacketed surface area on the pump case and PRV that enables uniform heating whether using steam or hot oil
- Rotatable casing that enables both right-hand and left-hand flange orientations without additional costs or lead times
- Standard high-strength, ductile-iron gear material that improves reliability when compared to steel rotors, all while resulting in upwards of 25% in purchase-cost savings
- World's first drop-in replacement for the Viking® 34 Series Asphalt Pump

# EnviroGear V Series Pump

## First Drop-In Replacement for the Viking® 34 Series Asphalt Pump

The EnviroGear V Series is the first drop-in replacement for the Viking® 34 Series pump. Replacing an existing Viking pump usually requires no modification to the piping, driver, baseplate or coupling, while also keeping flow rates unchanged.

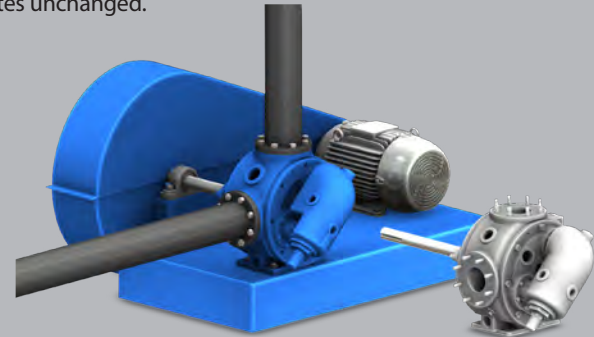

## Direct Replacement-Part Interchangeability

V Series components are part-for-part interchangeable with the Viking 34 Series pump and offer very specific design enhancements to improve reliability. This allows you to rebuild your existing pumps with high-quality EnviroGear components. Most parts ship in 3-5 business days. Expedite programs are also available.

## Flexible Port Orientation

V Series pumps are designed with a rotatable casing that allows the operator to use both right-hand and left-hand flange orientations as needed. This reduces additional costs and lead times associated with left-hand (LH) configuration pumps.

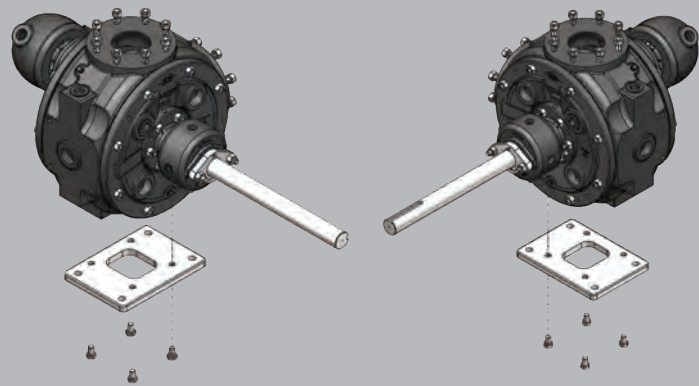

## Internal Clearance Options

A wide range of internal clearance options are available, which allows optimal performance in a wide range of applications

## Hardened Idler Pin

Standard on all pump sizes for maximized operational life

## Rear Plate with Jacketing

Provides jacketing behind the rotor to eliminate cold spots

## Seal Chamber with Flexible Design

Seal chamber accepts a wide range of sealing technologies, including packing, cartridge triple-lip seal and cartridge mechanical seal

## High-Strength Rotor Standard

High-strength, ductile-iron rotor comes standard on all sizes, eliminating the need for costly, long lead-time steel rotors

## Jacketed Head with PRV

Jacketed head designed to incorporate an optional pressure relief valve (PRV), offering pressure protection with improved head heating

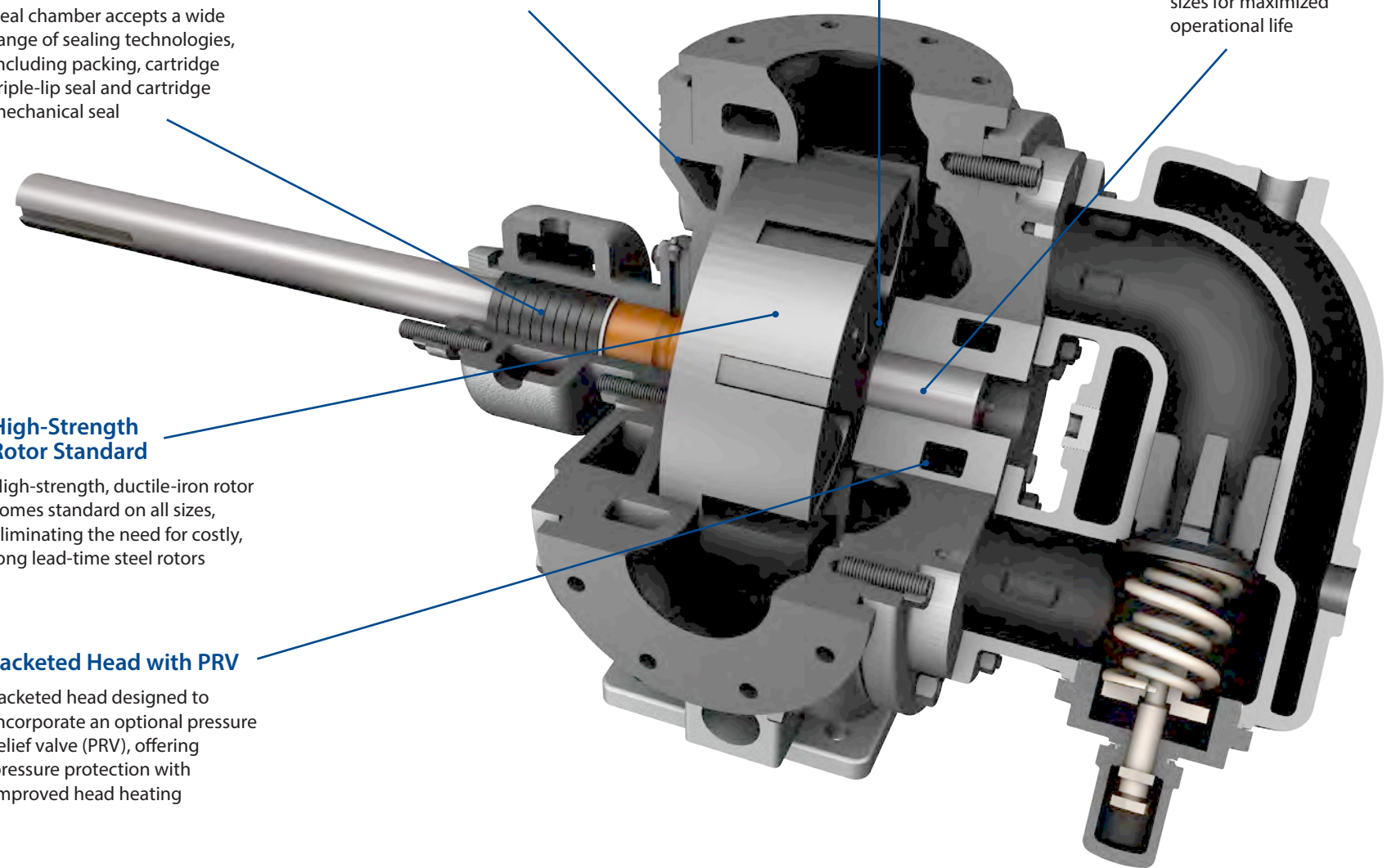

## Maximized Jacket Surface Area

Jacketing on the pump case, head, pressure relief valve, rotor-bearing sleeve and rear adapter plate have been maximized to allow more uniform heating and quicker time to reach operating temperature, which improves system reliability.

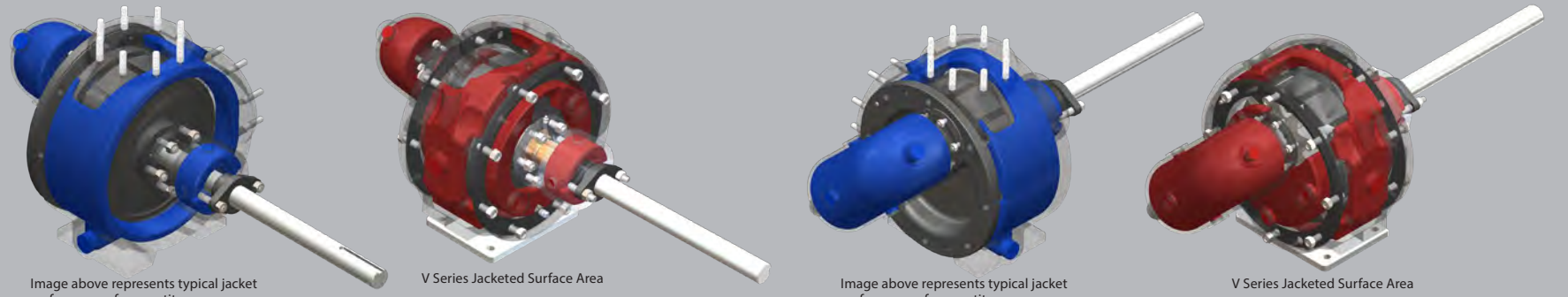

## Sizes Available

Pump Model	Port Sizes <sup>1</sup>	Pump Only
V2-55	2-1/2" ANSI	180 lb (82 kg)
V2-133	3" ANSI	350 lb (160 kg)
V2-254	4" ANSI	530 lb (240 kg)
V2-423	5" ANSI	750 lb (340 kg)

<sup>1</sup>Flanged connections meet Class 125# ANSI

## Pump Selection Performance Criteria

Pump Model	Nominal Pump Rating		<sup>1</sup> Max Discharge Pressure	Max Temperature
	RPM	GPM (m <sup>3</sup> /h)	PSIG (BAR)	Fahrenheit (Celcius)
V2-55	420	90 (20)	100 (6.9) >20 cSt	450° (232°)
V2-133	350	200 (45)	75 (5.2) >20 cSt	450° (232°)
V2-254	280	280 (64)	75 (5.2) >20 cSt	450° (232°)
V2-423	280	450 (102)	75 (5.2) >20 cSt	450° (232°)

<sup>1</sup>Maximum pressure listed reflects maximum differential pressure and maximum allowable working pressure

<sup>2</sup>Values listed in table are nominal and for reference only. To ensure proper pump selection, always refer to EnviroGear CHOICE.

## Materials of Construction

Description	Part	Cast Iron
Pressure Containing Components	Pressure Relief Valve	Cast Iron, ASTM A48, Class 35B
	Head	Cast Iron, ASTM A48, Class 35B
	Case	Cast Iron, ASTM A48, Class 35B
	Bracket	Cast Iron, ASTM A48, Class 35B
	Rear Plate	Cast Iron, ASTM A48, Class 35B
	Rotor Bearing Sleeve (RBS)	Cast Iron, ASTM A48, Class 35B
	Packing Gland	Cast Iron, ASTM A48, Class 35B
Product Contact	Idler Gear	Ductile Iron, ASTM A536, Grade 80-55-06
	Rotor	Ductile Iron, ASTM A536, Grade 80-55-06
	Shaft	Carbon Steel, ASTM A311/A311M, Grade 1045, Class B
	Idler Pin	Hardened Steel, ASTM A311/A311M, Grade 1035, Class A/Carburized
	Idler Bushing	Carbon Graphite, Bronze, Tungsten Carbide
	Thrust Washer - Rotating	Hardened Alloy Steel, Grade 52100
	Thrust Washer - Stationary	Bronze, SAE 660, Grade C93200
	RBS Bushing	Bronze, ASTM B505/B505M, Grade C93700
Retaining Washer	Carbon Steel, ASTM A311/A311M, Grade 1045	
Non-Product Contact	Foot	ASTM A36 Steel

## Model Cross Reference

V Series	G Series	E Series	Viking®
V2-55	G1-55	E1-55	LQ34
V2-133	G1-133	E1-133	Q34
V2-254			M34
V2-423			N34

Viking® is a registered trademark of Viking Pump, Inc., a unit of IDEX Corporation.

## Where Innovation Flows



PSG  
22069 Van Buren Street  
Grand Terrace, CA 92313-5651  
P: +1 (909) 422-1731 • F: +1 (909) 783-3440  
[envirogearpump.com](http://envirogearpump.com)

PSG® reserves the right to modify the information and illustrations contained in this document without prior notice. This is a non-contractual document. 04-2018

**Authorized PSG Partner:**

ООО "ТЕХНО-ГРУПП", ИНН 5027203832  
195113, г. Санкт-петербург, Новочеркасский пр., д. 58, оф. 511  
115533, г. Москва, Андропова пр., д. 22, пом. 1, комната 43  
T: 8 (800) 350-01-06 ; +7 (499) 404-15-22  
E: [info@tehnogrupp.com](mailto:info@tehnogrupp.com)  
[www.tehnogrupp.com](http://www.tehnogrupp.com)